

Estd: 2008

METHODIST

COLLEGE OF ENGINEERING & TECHNOLOGY

Approved by AICTE New Delhi | Affiliated to Osmania University, Hyderabad

Abids, Hyderabad, Telangana, 500001

DEPARTMENT OF MECHANICAL ENGINEERING

LABORATORY MANUAL

METROLOGY & MACHINE TOOLS LABORATORY

BE V Semester

AUTONOMOUS

Name:

Roll No:

Branch:.....SEM:.....

Academic Year:

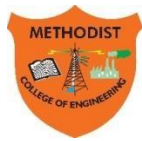

Estd: 2008

METHODIST

COLLEGE OF ENGINEERING & TECHNOLOGY

Approved by AICTE New Delhi | Affiliated to Osmania University, Hyderabad
Abids, Hyderabad, Telangana, 500001

VISION

To produce ethical, socially conscious and innovative professionals who would contribute to sustainable technological development of the society.

MISSION

To impart quality engineering education with latest technological developments and interdisciplinary skills to make students succeed in professional practice.

To encourage research culture among faculty and students by establishing state of art laboratories and exposing them to modern industrial and organizational practices.

To inculcate humane qualities like environmental consciousness, leadership, social values, professional ethics and engage in independent and lifelong learning for sustainable contribution to the society.



Estd:2008

METHODIST

COLLEGE OF ENGINEERING & TECHNOLOGY

Approved by AICTE New Delhi | Affiliated to Osmania University, Hyderabad

Abids, Hyderabad, Telangana, 500001

DEPARTMENT OF MECHANICAL ENGINEERING

LABORATORY MANUAL

METROLOGY & MACHINE TOOLS LABORATORY (6PC556ME)

Prepared by

PART-A

Mrs. I. Sowjanya, Associate Professor. Mech. Engg.

PART-B

Dr. P. Prabhu Raj, Associate Professor. Mech. Engg.

DEPARTMENT OF MECHANICAL ENGINEERING

VISION

To be a reputed centre of excellence in the field of mechanical engineering by synergizing innovative technologies and research for the progress of society.

MISSION

- To impart quality education by means of state-of-the-art infrastructure.
- To involve in trainings and activities on leadership qualities and social responsibilities.
- To inculcate the habit of life-long learning, practice professional ethics and service the society.
- To establish industry-institute interaction for stake holder development.

DEPARTMENT OF MECHANICAL ENGINEERING

After 3-5 years of graduation, the graduates will be able to:

PEO1: Excel as engineers with technical skills, and work with complex engineering systems.

PEO2: Capable to be entrepreneurs, work on global issues, and contribute to industry and society through service activities and/or professional organizations.

PEO3: Lead and engage diverse teams with effective communication and managerial skills.

PEO4: Develop commitment to pursue life-long learning in the chosen profession and/or progress towards an advanced degree

DEPARTMENT OF MECHANICAL ENGINEERING

PROGRAM OUTCOMES

Engineering Graduates will be able to:

PO1. Engineering knowledge: Apply the basic knowledge of mathematics, science and engineering fundamentals along with the specialized knowledge of mechanical engineering to understand complex engineering problems.

PO2. Problem analysis: Identify, formulate, design and analyse complex mechanical engineering problems using knowledge of science and engineering.

PO3. Design/development of solutions: Develop solutions for complex engineering problems, design and develop system components or processes that meet the specified needs with appropriate consideration of the public health and safety, and the cultural, societal, and environmental considerations.

PO4. Conduct investigations of complex problems: Formulate engineering problems, conduct investigations and solve using research-based knowledge.

PO5. Modern tool usage: Use the modern engineering skills, techniques and tools that include IT tools necessary for mechanical engineering practice.

PO6. The engineer and society: Apply the contextual knowledge to assess societal, health, safety, legal and cultural issues and the consequent responsibilities relevant to the professional engineering practice.

PO7. Environment and sustainability: Understand the impact of the professional engineering solutions in societal and environmental contexts, and demonstrate the knowledge of, and need for sustainable development.

PO8. Ethics: Apply ethical principles and commit to professional ethics and responsibilities during professional practice.

PO9. Individual and team work: Function effectively as an individual, and as a member or leader in diverse teams, and in multidisciplinary settings.

PO10. Communication: Communicate effectively on complex engineering activities to various groups, ability to write effective reports and make effective presentations.

PO11. Project management and finance: Demonstrate and apply the knowledge to understand the management principles and financial aspects in multidisciplinary environments.

PO12. Life-long learning: Recognize the need for, and have the preparation and ability to engage in independent and life-long learning in the broadest context of technological change.

PROGRAM SPECIFIC OUTCOMES

Mechanical Engineering Graduates will be able to:

PSO1: Apply the knowledge of CAD/CAM/CAE tools to analyse, design and develop the products and processes related to Mechanical Engineering.

PSO 2: Solve problems related to mechanical systems by applying the principles of modern manufacturing technologies.

PSO 3: Exhibit the knowledge and skill relevant to HVAC and IC Engines.

CODE OF CONDUCT

1. Students should report to the concerned labs as per the time table schedule.
2. Students who turn up late to the labs will in no case be permitted to perform the experiment scheduled for the day.
3. After completion of the experiment, certification of the concerned staff in-charge in the observation book is necessary.
4. Staff member in-charge shall award marks based on continuous evaluation for each experiment out of maximum 15 marks and should be entered in the evaluation sheet/attendance register.
5. Students should bring a note book of about 100 pages and should enter the readings/observations into the notebook while performing the experiment.
6. The record of observations along with the detailed experimental procedure of the experiment performed in the immediate last session should be submitted and certified by the staff member in-charge.
7. Not more than three students in a group are permitted to perform the experiment on a setup for conventional labs and one student in case of computer labs.
8. The components required pertaining to the experiment should be collected from stores in-charge after duly filling in the requisition form.
9. When the experiment is completed, students should disconnect the setup made by them, and should return all the components/instruments taken for the purpose.
10. Any damage of the equipment or burn-out of components will be viewed seriously either by putting penalty or by dismissing the total group of students from the lab for the semester/year.
11. Students should be present in the labs for the total scheduled duration.
12. Students are required to prepare thoroughly to perform the experiment before coming to Laboratory.

DO'S

1. All the students are instructed to wear protective uniforms, shoes & identity cards before entering into the laboratory.
2. Please follow instructions precisely as instructed by your supervisor. If any part of the equipment fails while being used, report it immediately to your supervisor.
3. Take proper guidance before performing any experiment on the machine..
4. Students will not be permitted to attend the laboratory unless they bring the practical record fully completed in all respects pertaining to the experiment conducted in the previous class.
5. Practical records should be neatly maintained.
6. Students should obtain the signature of the staff-in-charge in the observation book after completing each experiment.
7. Theory regarding each experiment should be written in the practical record before procedure in your own words.
8. One student from each batch should put his/her signature during receiving the instrument in the instrument issue register.

DON'TS

1. Don't operate any instrument without getting concerned staff member's prior permission. Handle equipment carefully to avoid breakage.
2. Using the mobile phone in the laboratory is strictly prohibited.
3. Do not touch the workpiece after completion of the experiment, because due to friction it gets heated.
4. Do not leave the experiments unattended while in progress.
5. Do not crowd around the equipment & run inside the laboratory.
6. Don't wear loose torn clothing of any kind.
7. Do not wander around the lab and distract other students
8. Do not use any machine that smokes, sparks, or appears defective.
9. Handle the Instruments carefully as they are very sensitive in providing the accurate Result.
10. Ask for the help of Instructor/Faculty while doing the experiments on costly & sophisticated equipment like Tool makers Microscope, Surface Roughness Tester, LVDT, Thermocouples & Strain Gauges

COURSE OBJECTIVES

The objectives of this course are

1.	To have knowledge of various precision measuring instruments.
2.	To familiarise machining and metal cutting operations.

COURSE OUTCOMES

CO No.	Course Outcomes	PO
CO 1	Identify and use various instruments for external, internal and angular measurements	1, 6, 7, 8, 9, 10
CO 2	Apply the principles of optical measurements in measuring the screw.	1, 6, 7, 8, 9, 10
CO 3	Identify and use various types of force and temperature measurement instruments/tools.	1, 6, 7, 8, 9, 10
CO 4	Apply the knowledge of metal cutting principles to perform various machine tool operations.	1, 6, 7, 8, 9, 10
CO 5	Determine Shear angle, cutting forces, temperatures and tool life in metal cutting processes	1, 6, 7, 8, 9, 10

COURSE OUTCOMES VS POs MAPPING

S. NO	PO1	PO2	PO3	PO4	PO5	PO6	PO7	PO8	PO9	PO10	PO11	PO12	PSO1	PSO2	PSO3
6PC556ME.1	3.0	-	-	-	-	1.0	2.0	1.0	2.0	1.0	-	-	-	3.0	-
6PC556ME.2	3.0	-	-	-	-	1.0	2.0	1.0	2.0	1.0	-	-	-	3.0	-
6PC556ME.3	3.0	-	-	-	-	1.0	2.0	1.0	2.0	1.0	-	-	-	3.0	-
6PC556ME.4	3.0	-	-	-	-	1.0	2.0	1.0	2.0	1.0	-	-	-	3.0	-
6PC556ME.5	3.0	-	-	-	-	1.0	2.0	1.0	2.0	1.0	-	-	-	3.0	-
Avg	3.0	-	-	-	-	1.0	2.0	1.0	2.0	1.0	-	-	-	3.0	-

LIST OF EXPERIMENTS

Exp. No.	Experiment Name	Page No.
PART-A METROLOGY & INSTRUMENTATION LAB		
1.	Measurement of Length and Height by using Vernier Calipers and Vernier Height Gauge	02
2.	Measurement with Inside, Depth and Outside Micrometer	10
3.	Measurement of Angles with Sine Bar and Bevel Protractor	21
4.	Measurement With Dial Indicator and Dial Bore Gauge	30
5.	Measurement of Roundness Errors with Bench Centers, V-Block and Dial Gauge	37
6.	Measurement of Linear and Angular dimensions with Tool Maker's Microscope	42
LIST OF ADDITIONAL EXPERIMENTS		
7.	Testing a specimen roughness by Surface Roughness Tester	48
8.	Measurement of Angle using Gear Tooth Vernier	54
PART-B MACHINING OPERATIONS & METAL CUTTING LAB		
9.	Typical exercises on lathe machine(Turning, Step turning, Facing, Parting off &Taper turning).	63
10.	Thread cutting exercise on lathe machine as single start and multi start threads.	69
11.	Exercise of simple gear manufacturing on milling machine.	74
12.	Production of thread with tap and threading dies and milling cutters.	80
13.	Typical exercises on shaper, cylindrical grinding machine.	85
14.	Measurement of Cutting forces with Lathe tool dynamometer and determination of friction angle and stresses on shear plane and rake plane.	91
15.	Estimation of shear angle by measuring thickness and length of chips.	97
16.	Study of geometrical tests on lathe machine.	103
LIST OF ADDITIONAL EXPERIMENTS		
17.	Practicing Drilling & Boring operations on the given specimen	110
18.	Grinding various tool angle according to ASA of given tool signature	115

Note: At least ten experiments should be conducted

PART-A

**METROLOGY &
INSTRUMENTATION LAB**

EXPERIMENT - 01

MEASUREMENT OF LENGTH AND HEIGHT BY USING VERNIER CALIPERS AND VERNIER HEIGHT GAUGE

AIM:

To measure lengths and heights of the given object using vernier calipers and vernier height gauge

APPARATUS:

- Vernier Caliper
- Vernier Height Gauge

THEORY:

Learning objectives:

Intellectual skills

- 1) To understand the construction and working of linear measurement instruments.
- 2) To understand the concept of least count of given measuring instrument.

Motor skills

- 1) Ability to handle measuring instruments.
- 2) Ability to set instruments for zero error using master pieces.
- 3) Ability to calculate least count of the measuring instrument.
- 4) Ability to note the readings of dimensions of given components.

Specifications:

Vernier calipers: range = -----mm, Least Count = ----- mm

Vernier height gauge: range = -----mm, Least Count =----- mm

Working Principle:

Vernier calipers: The principle of Vernier is that when two scales or divisions slightly different in size are used, the difference between them can be utilized to enhance the accuracy of measurement.

$$(n-1)* MSD = n* VSD$$

I.e. n-1 divisions on main scale are equal to 'n' divisions on Vernier scale.

Vernier height gauge: This also works on the same principle on which Vernier calipers works i.e.

$$(n-1)* MSD = n* VSD$$

Vernier calipers:

Pierre Vernier, a Frenchman, devised principle of Vernier for precise measurements in 1631. It consists of two scales. One is fixed and the other is movable. The fixed scale is called main scale and it is calibrated on an L- shaped frame and carries a fixed jaw. The movable scale called Vernier scale slides over the main scale and carries a movable jaw. The movable jaw as well as fixed jaw carries measuring tip. When two jaws are closed, the zero of the Vernier scale

coincides with the zero of the main scale. For precise setting of the movable jaw an adjustable screw is provided. Also an arrangement is provided to lock the sliding scale on the fixed main scale.

Main scale:

On the main scale one cm is divided into 10 divisions. So each division is equal to 1/10 cm or 1mm

Vernier scale:

On the Vernier scale a distance of 49mm is divided into 50 equal divisions. So each division is equal to 49/50mm

$$1 \text{ VSD} = 49/50 \text{ mm}$$

Least count of an instrument:

The accuracy of any instrument depends on its least count. The least count is the smallest value that can be measured by an instrument accurately.

The least count of Vernier Calipers is equal to the difference of 1 MSD and 1 VSD.

$$\text{L.C} = 1 \text{ MSD} - 1 \text{ VSD} = 1 - 49/50 = 0.02\text{mm}$$

The L.C of the Vernier scale can be found directly by applying formula

$$\text{L.C} = S/N$$

S= value of one MSD

N = No. of divisions on Vernier scale

$$\text{LC} = 1/50 = 0.02\text{mm}$$

Sizes available:

With least count of 0.01, 0.02, 0.05, 0.1mm in size ranges of 0-125, 0-200, 0-300mm

Uses:

Vernier calipers can be employed for both internal and external measurements. Lengths can be measured accurately up to 1/50 mm. It is used to determine the lengths, heights and diameters.

Length of an object:

When an object is gripped between the two measurements, the zero of the Vernier shifts towards right crossing certain number of complete main scale divisions and a fraction of the main scale division. The extra length of the object covering fraction of the main scale division is measured by means of the Vernier.

$$\text{Extra length of the object (b)} = \text{Vernier coincidence} * \text{L.C}$$

Therefore

$$\text{Total length of the object} = \text{MSR} + \text{extra length}$$

Vernier height gauge:

Vernier height gauge consists of a base, beam, measuring jaw and a scribe. The base is made to ample proportions to ensure rigidity and stability of the gauge. The underside of the base is relieved and an air gap is provided across the surface to connect the relieved part with the outside.

The beam's section is chosen such that it ensure tightly during use. The guiding edge of beam should be perfectly flat within the tolerances of 0.02, 0.04, 0.06 and 0.08 mm for measuring range of 250,500,750 and 1000mm respectively. The faces of the beam should be flat. The clear projection of the measuring jaw from the edge of the beam should be at least equal to

the projection of the base from the beam. For all positions of the slides the upper and lower gauging surface of the measuring jaws so that it can be reversed and should confirm to this depth to within 0.013mm. The actual depth of the scribed is clearly marked on it.

Vernier Scales

Vernier scales have normal scale components, but also incorporate a small secondary scale that subdivides major increments. This secondary scale is based on a second scale that is one increment shorter than a main scale. If the secondary scale is compared to the main scale, it will indicate relative distance between two offsets.

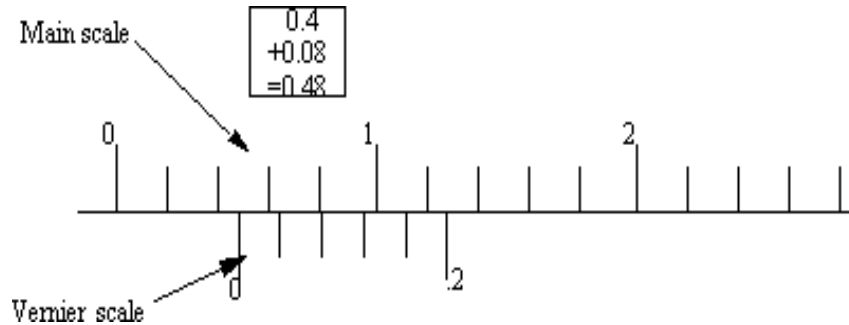

The scale pictured above would normally be on an instrument, and the main and Vernier scales would slide relative to each other. The '0' on the Vernier scale would be used to take the reading from the main scale. In this example the main scale would read a value that is between 0.4 and 0.6. (Note: it is not considered good practice to round this to 0.5)

The Vernier scale can then be used to find the internal division, by looking for where the divisions in the top and bottom scales align. In this case the second internal division aligns with 1. Using the values on the Vernier scale, we can see that the value for this division would be

The value from the Vernier scale is added directly to the main scale value to get more accurate results. $0.4 + 0.08 = 0.48$. On metric sliding Vernier scales the main scale divisions are 1mm apart, and the Vernier scale they are 0.98 mm, giving a reading of 0.02mm per graduation.

Angular Vernier scales are used on protractors, and are identical in use to linear Vernier scales. The major protractor scales have divisions of 1 degree, and the Vernier scale is divided into 5 minute intervals. One interesting note is that the Vernier scale has two halves, one in the positive direction, and one in the negative direction. If reading from the left division on the main scale, the right Vernier scale should be used. And, when measuring from the right hand division on the major scale, the left Vernier scale should be used.

PROCEDURE:

Vernier calipers

1. When two measuring tip surfaces are in contact with each other check for the zero error.
2. First the whole movable jaws assembly is adjusted so that the two measuring tips just touch the part to be measured.
3. Then lock nut is tightened. Final adjusted so that depending upon the sense of correct feel is made by adjusting screws.
4. After final adjustment has been made the locking nut 'A' is also tightened and reading is noted.

5. The division which is nearer to the Vernier zero is the MSR. The Vernier scale division is that which exactly coincides with one of the MSD.
6. The final reading is calculated with the help of MSD, VSD and the LC of Vernier and thus all the measurements are made.

Vernier height gauge:

1. The base of the height gauge is firstly placed on a flat surface and is checked for zero error.
2. The specimen is then placed on the flat surface and the slider is moved with the help of a slider clamping screw and the measuring jaw is placed on the surface of the specimen.
3. Now the measuring jaw is firmly clamped.
4. The readings are noted; in a similar way as in Vernier calipers and the final measurements are made.

Tabular Column

Vernier calipers Range: -----, L.C = -----mm, Error=-----, Correction=-----,

S. No	MSR in mm (a)	Vernier coincidence (n)	Extra length $b = n * L.C$	Total length = (a+ b± Correction) mm
L1				
L2				
L3				

Vernier height gauge Range: -----, L.C = -----mm, Error=-----, Correction= ----- ,

S No	MSR (a) mm	Vernier coincidence (n)	VSR $b = n * L.C$	Total length = (a+ b± Correction) mm
H1				
H2				
H3				

Precautions:

1. The line of measurement must coincide with the line of scale
2. While measuring the outside diameter, the plane of the measuring tip of the calipers must be perpendicular to the centerline of the workpiece. The calipers should not be tilted or twisted.
3. Move the caliper jaws on the work with light touch. Do not apply undue pressure.

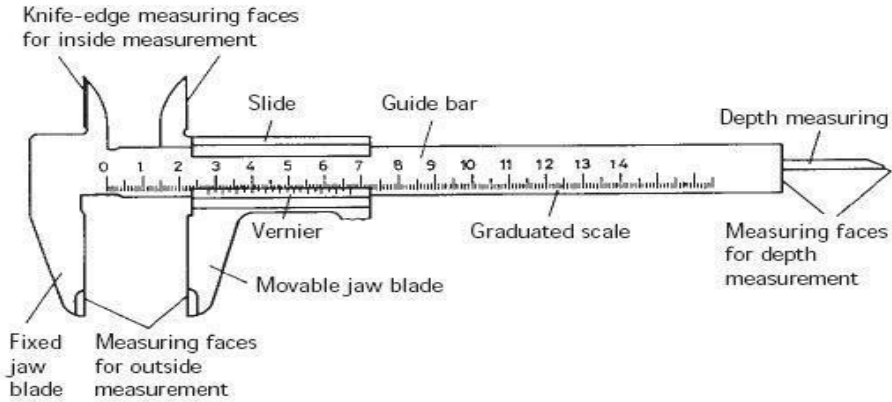

Caliper and Vernier

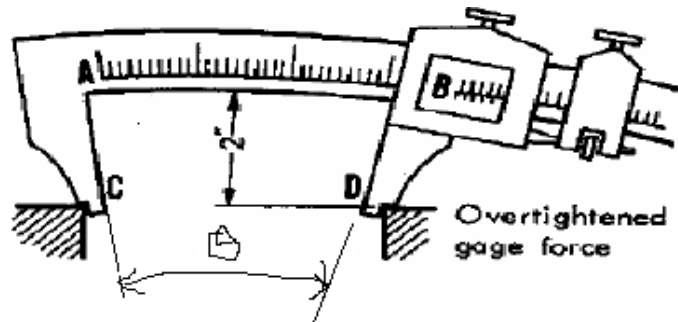

$$\text{Error} = \text{offset} * \text{angle}$$

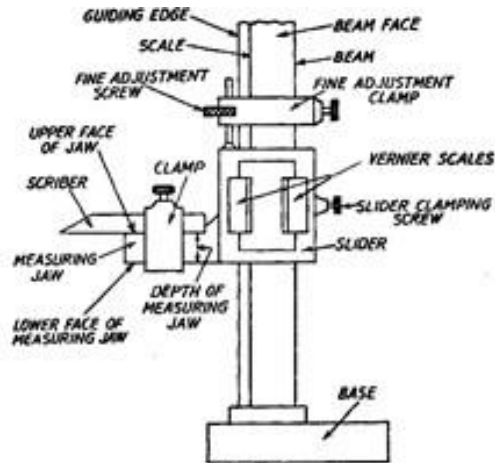

Vernier Height Gauge

Space For Calculations

RESULT & CONCLUSIONS:

The lengths and heights of the given specimen are found by using Vernier calipers and Vernier height gauge.

VIVA QUESTIONS:

- What are measurement standards?
- What effect will temperature variation have on precision measurements?
- How can a Vernier scale provide higher accuracy?
- What are dimensional tolerances, and what are their primary uses?
- Why is an allowance different from a tolerance?
- What are fits?
- What is the difference between precision and accuracy?
- If a steel ruler expands 1% because of a temperature change, and we are measuring a 2" length, what will the measured dimension be?
- What are the applications of Vernier calipers?
- Draw the scale for a Vernier reading 15.64 mm.

EXPERIMENT - 02

MEASUREMENT WITH INSIDE , DEPTH AND OUTSIDE MICROMETER

AIM:

To measure the diameters and depths of a given specimens using outside and depth micrometer. And to measure the diameter of the bore of a given component using inside micrometer

APPARATUS:

- outside micrometer
- depth micrometer
- Inside micrometer,
- Vernier calipers
- Steel rule

THEORY:

Learning objectives:

Intellectual skills

- 1) To understand the construction and working of linear measurement instruments.
- 2) To understand the concept of least count of given measuring instrument.

Motor skills

- 3) Ability to handle measuring instruments.
- 4) Ability to set instruments for zero error using master pieces.
- 5) Ability to calculate least count of the measuring instrument.
- 6) Ability to note the readings of dimensions of given components.

Specifications:

Outside micrometer: range = mm, Least Count = mm

Depth micrometer: range = mm, Least Count = mm

Inside micrometer: range = , Least Count =

Micrometer

Micrometers are designated according to screw and nut principle where a calibrated screw thread and circular scale divisions are used to indicate the principle practical part of main scale divisions.

The micrometer consists of U- shaped frame 'F' with a shaft and fixed at one end and a hollow cylinder 'A' attached to the other end. A screw S_1 works through the thread at the inner surface of the cylinder A. A metallic cap B attached to knurled head is useful for just gripping the body in between the shafts. When body got just gripped, the knurled head makes some sound on

rotation, without further pushing the shaft. The ends of the shaft S and the screw S_1 are parallel to each other. The cap B provided with a shaping edge 'E' which is divided into 100 equal divisions and is called head scale H. There is a line parallel to the axis of the cylinder called index line which is graduated in mm. This scale is called pitch scale P.

Pitch of the screw: The linear distance advanced by the screw S_1 on the pitch scale for one complete rotation of the head is called the pitch of the screw. (i.e. the distance between two consecutive threads of the screw).

Pitch = (distance moved on pitch scale by screw) / (one complete rotation of the head scale)

Least count of the micrometer (L.C): The distance traversed by the screw on the pitch scale when the head rotated through one head scale division is called least count of the micrometer

L.C = pitch of screw / No. of head scale divisions

Zero error: Before taking the observations, zero error on the micrometer has to be noted. The head of the screw is rotated until the screw S_1 just touches the fixed shaft S.

- 1) If the zero division of the head scale exactly coincides with the zero division of the pitch scale, then there is no error and correction will not be applied.

Zero error= 0 divisions

Correction = 0 divisions

- 2) If the zero division of the head scale above the pitch scale line (say 5 divisions) then the error is negative and correction is positive. In this case ,

Zero error = -5 divisions

Correction = +5 divisions

- 3) If the zero division of the head scale below the pitch scale line (say 5 divisions) then the error is positive and the correction is negative. In this case,

Zero error = +5 divisions

Correction= -5 divisions

The above correction has to be added to the observed head scale coincidence while taking the observations.

USES:

The outside micrometer is used to make small measurements like diameters, thickness etc.

Sizes available:

0-25, 25-50, 50-75, 75-100, 100-125 mm etc

After finding the least count, the zero error of the screw, the given specimen is gripped between the shaft S and screw S_1 and readings on the pitch scale and head scale coincidence (i.e. the divisions on the head scale coincidence with the index line) are noted and the average diameter of the cylinder is calculated.

Depth micrometer:

Depth micrometer has got one shoulder which acts as reference surface and is held firmly and perpendicular to the centre line of the hole. Here also for larger measurements extension rods are used. The screw of micrometer depth gauge has a range of 20mm or 25mm. The length of the micrometer depth gauge varies from 0 to 225mm. The rod is inserted through the top of micrometer. The rod is marked after every 10mm so that it could be clamped at any position.

Inside micrometer:

The inside micrometer is used for measuring large internal dimensions to an accuracy of 0.01mm. In principle it is similar to an external micrometer and is used for measuring holes with a diameter over 50mm. It consists of the following main parts

- (1) Measuring head (micrometer unit)
- (2) Extension rods
- (3) Spacing rods
- (4) Handle

Measuring head:

It consists of barrel and thimble similar to external micrometer. It has no frame and spindle. The measuring points are at extreme ends and adjustment is affected by advancing and withdrawing the thimble along the barrel. The distance between the measuring faces of the micrometer can vary from 50 to 63 mm. To measure the holes with a diameter over 63mm, the micrometer is fitted with extension rods of various sizes.

Reading the micrometer unit:

- (1) The barrel has graduations in intervals of 1mm above the reference line. There are also graduations below the reference line at the middle of the two successive graduations so as to read 0.5mm.
- (2) For measuring the particular dimension, take the reading on the main scale considering the account of divisions on the reference line.
- (3) Take the thimble reading which coincides with the reference line on the sleeve.
- (4) Total reading = Main scale reading + (least count * reading on the thimble)

Extension rods:

These are used to measure holes with a diameter over 63 mm which are fitted in the micrometer unit. The following sizes (in mm) of extensions rods are available 12,25,50,75,100,125,150 &175

Spacing collars and handle:

Spacing collars are used for taking additional measurements. Handle is fixed into the measuring head to measure deep cylindrical holes.

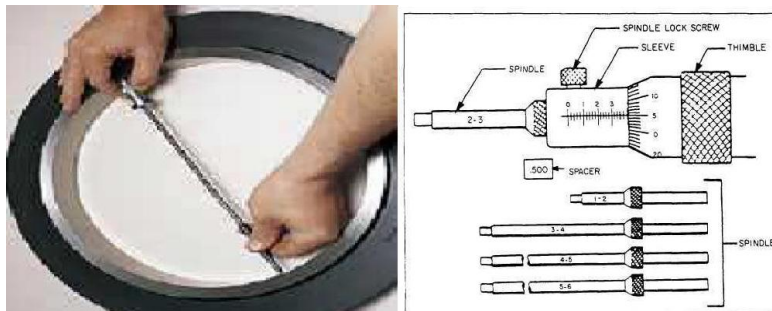

PROCEDURE:

Outside micrometer

1. Check for zero error by bringing the anvil and spindle into close contact.
2. The specimen is placed between the anvil and spindle by rotating the thimble and is fixed in position using locknut.
3. When the spindle is brought into contact with the work at the correct measuring pressure, the clutch starts slipping and no further movement of the spindle takes place by the rotation of ratchet.
4. Now the reading on the barrel is noted down which corresponding to the main scale reading.
5. Then the reading on the thimble corresponding to the pitch scale reading is noted.
6. Then the final reading is calculated.

Depth micrometer:

1. Check for zero error by taking the dimension standard sizes specimen.
2. The shoulder which acts as reference surface and is held firmly and perpendicular to the centerline of the hole.
3. If necessary, extensions are used according to the measurement.
4. The scale here is calibrated in reverse direction.
5. The accuracy depends on the sense of touch.

Inside micrometer:

1. For taking measurements of a given specimen, first the diameter of the bore is to be measured approximately by Vernier calipers or steel rule.
2. Select extension rod to the nearest one and insert in micrometer head.
3. Check the zero error by dimension on standard sized specimen.
4. Adjust the micrometer at a dimension slightly smaller than the diameter of the bore.
5. The micrometer head is then held firmly against the bore and other contact surface is to be adjusted by moving the thimble till the correct feel is sensed.
6. Move one contact surface up and down to ensure that full diameter is measured.
7. Remove the micrometer and take the reading.
8. The length of extension rod and collar has to add to the micrometer reading.
9. Take at least three readings at different locations of the bore. Finally take the average.

Tabular Column

Outside micrometer Range: -----, L.C= ; Error = ; Correction = ;

S.No	P.S.R in mm (a)	Head scale coincidence (n)	H.S.R (b) = n*L.C in mm	Diameter=a+b± Correction in mm

Depth micrometer Range: -----, L.C= ; Error = ; Correction = ;

S. No	P.S.R in mm (a)	H.S coincidence (n)	H.S.R (b) = n*L.C in mm	Depth = (a+b) \pm correctio n in mm

Inside micrometer Range: -----, L.C= ; Error = ; Correction = ;

S.No	Micrometer reading (mm)	Space length(mm)	Extension in rod length(mm)	Total diameter (mm)

Calibration of micrometer screw

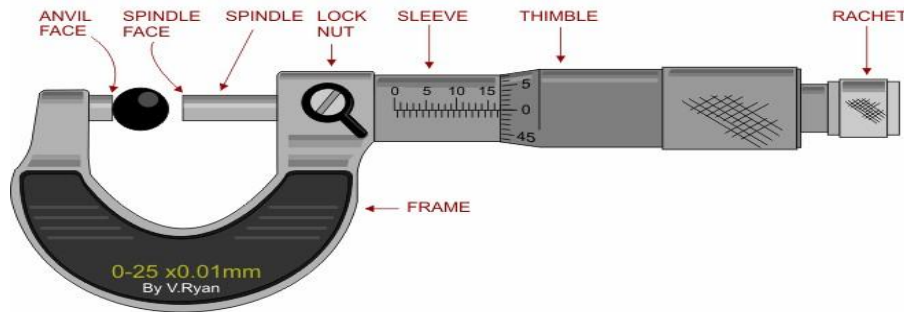

The accuracy of any gauge may be checked with the following steps for calibration. Calibration is another way of saying, "checking for accuracy." Calibration is the process for ensuring the accuracy of gauges. The process involves a gauge block and the micrometer. A gauge block is a block made from steel that is cut to size within a millionth of an inch. Gauge blocks come in various sizes and are used to check the accuracy of measuring devices such as a micrometer.

1. Use a gauge block that falls within the limits of the gauge's range.
2. Snug the gauge block between the spindle and anvil of the micrometer using appropriate feel.(see fig)



3. Use the ratchet stop as explained in step 2 under zero checking until you have a comfortable feel between the gage and the gage block.
4. Confirm calibration by checking that the display shows the dimension of the gage block.
5. Again, you may want to insure calibration by repeating these steps more than once.
6. If the reading on the micrometer display shows the gage block's dimension, you may begin using the micrometer for measuring. The micrometer may also be checked for calibration using other gage blocks within its range.
7. Using other blocks that fall within the range of the gage will test the gage's accuracy from one end of the spindle to the other. This may also uncover problems and explain why the gage is losing accuracy.
8. Errors in screw threads may be of three types, namely progressive, periodic and erratic. The method of manufacture of micrometer screws eliminates the last of these, but there may be a progressive error and also a periodic error in the readings, which is usually caused by the eccentricity of the thimble.
9. The method of finding the errors in an external micrometer is by taking the readings over slip gauges, the sizes of which must be chosen to disclose the both types of error. A sufficient number of readings for the progressive error is obtained by using slips in steps of 2.5 mm, and for periodic error by taking five readings during one revolution of the thimble. It is advisable to check the periodic error at two positions of the spindle, one near at each end of its travel. Suitable slip gauges for testing a 0.25 mm micrometer are therefore
10. For the progressive error – 2.5 to 25 in steps of 2.5 mm
11. For the periodic error -2.1 to 2.5 in steps of 0.1 mm
12. The slips in the latter series are wrung on to the 20 mm slip to obtain readings for the periodic error near to the fully open position of the micrometer.
13. To avoid errors caused by expansion in handling, the micrometer should be clamped to the suitable stand and the slip gauges laid out in readiness some ten minutes before required, being held in tongs or with a piece of chamois leather during use. It is very important to apply the same pressure on each slip gauge. To ensure this, the spindle must be rotated very slowly during the last part of a revolution until a ratchet slips by one click.
14. Readings of the micrometer are taken, first with the measuring faces in contact and then over each slip gauge in turn, the results being recorded as plus or minus errors in units of 0.001 mm. From the readings, two graphs of errors should be drawn; one for the progressive error and the second, to a larger scale, for the periodic error. From these, the error in the micrometer at any nominal reading, and consequently the true size of the object measured, can be obtained.



Depth Micrometer and Its working

Micrometer Scales

This is a very common method for measuring instruments, and is based on the thread principle. In effect, as a thread is turned, a large motion on the outside of the thread will result in a very small advance in the position of the thread.

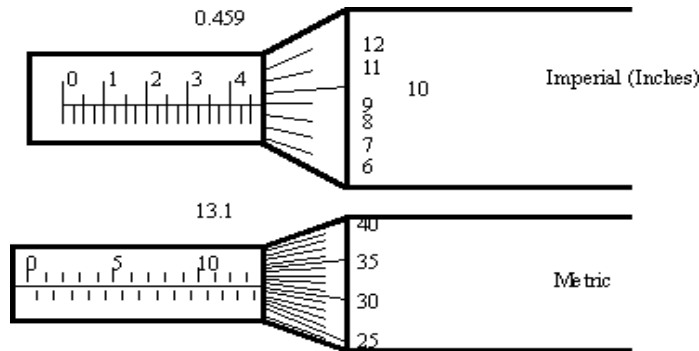

The micrometers pictured above have major scales, as well as minor scales. The major scales are read first, and the micrometer scales are read second and the readings added on. The metric micrometer above reads $13.5 = 13.5\text{mm}$ on the major scale, and $31 = .31\text{mm}$ on the thimble, for a total of 13.81mm . The Imperial scale above shows a micrometer reading of $4.5 = .45''$ on the main scale, and $9 = .009''$ on the thimble, for a total of $.459$. On imperial micrometers the divisions are typically $.025''$ on the sleeve, and $0.001''$ on the thimble. The thread used has 40 T.P.I. = a pitch of $0.025''$. Metric micrometers typically have 1 and 0.5 mm divisions on the sleeve, and 0.01mm divisions on the thimble. The thread has a pitch of 0.5mm.

A vernier micrometer has the scales as pictured above, but also a vernier scale is included to provide another place of accuracy. Depth micrometers have an anvil that protrudes, out the end, and as a result the scales are reversed to measure extension, instead of retraction.

Principle of Magnification

The operation of micrometers is based on magnification using threads. A large movement on the outside of the micrometer thimble will result in a small motion of the anvil. There are two factors in this magnification. First, the difference in radius between the thread and the thimble will give a change in sensitivity relative to the difference in radii. Second, the pitch of the thread will provide a reduction in motion.

The basic relationship can be seen below

$$M = \frac{C \pi D}{D \text{pitch}}$$

where,

M = magnification from the moving head to the hand motion
C = measuring diameter of the instrument
D = diameter of the thread
pitch = the number of threads per unit length

Radial Arm Principle of Magnification = $\frac{C}{D}$

Inclined Plane Principle of Magnification = $\frac{\pi D}{\text{pitch}}$

NOTE: magnification can result in greater sensitivity of an instrument to control, and reading by a user.

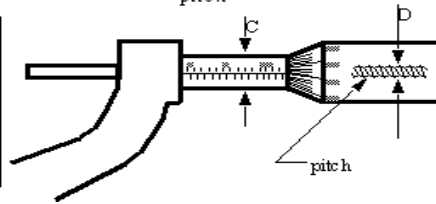

Principle of Alignment

Basically, the line of the physical measurement should be such that it is coincident with the measurement axis of the instrument. If the measurement is out of line, it may lead to misreading caused by deflections in the instrument.

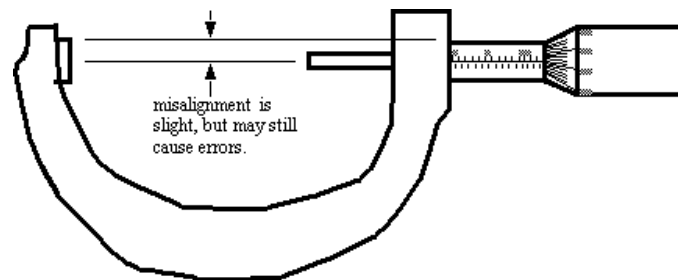

Micrometers are generally better than sliding Vernier calipers when considering this principle.

Precautions:

Outside micrometer:

1. First clean the micrometer by wiping off oil dirt ,dust and grit etc
2. Clean measuring faces of the anvil and spindle with a clean piece of paper or cloth.
3. Set the zero reading of the instrument before measuring
4. Hold the part whose dimension to be measured and micrometer properly. Then turn the thimble with proper finger and thumb till measuring tip touches the part and fine adjustment should be made by ratchet so that uniform measuring pressure is applied.
5. While measuring the dimensions of circular parts, the micrometer must be moved carefully over representative are so as to note maximum only.

Inside Micrometer

1. Avoid parallax error in the micrometer reading.
2. Extension rod should be properly fixed in the micrometer head by using stopper.
3. Clean the micrometer head and measuring faces of anvils by wiping oil, dirt and dust etc. by piece of paper or cloth.
4. Set the instrument to zero before measuring.

Space For Calculations

RESULT & CONCLUSIONS:

- The diameter and depth of the given object is found by outside micrometer and depth micrometer.
- The diameter of the bore of the given specimen is measured by using inside micrometer.

VIVA QUESTIONS:

- How the L.C. of a micro meter is found?
- What is meant by zero error of a micro meter?
- What is the degree of accuracy of the micro meter?
- What is meant by the pitch of a screw?
- What are “precision instruments”?
- How many divisions are graduated on thimble?
- What is the thimble diameter in the dial comparator bench micrometer?
- What is the total error in micrometer?

EXPERIMENT - 03

MEASUREMENT OF ANGLES WITH SINE BAR, BEVEL PROTRACTOR AND PRECISION LEVEL

AIM:

- a) To measure the taper angle of a given component using Sine bar
- b) To measure the angle between two faces of a given component using bevel protractor
- c) To measure the angle with combination Set

APPARATUS:

- Bevel protractor with Vernier and acute angle attachment (150/300 mm blades)
- Sine bar (150mm)
- Surface plate
- Gauge blocks
- Dial gauge(0.01 mm least count)
- Clamps for locking component to sine bar
- Combination Set

THEORY:

Sine principle and sine bar:

When a reference for a non-square angle is required, a Sine bar can be used. The sine principle uses the ratio of the length of two sides of a right angle triangle in deriving a given angle. The measurement is usually limited to 45 degrees from zero degrees. *The sine bar in itself is not a complete measuring instrument.* Another datum such as a surface plate is needed, as well as other auxiliary equipment notably gauge blocks and indicating device to make measurements. Sine bars are used either to measure angles very accurately or for locating any work to a given angle with in closed limits.

Sine bars are made from high carbon, chromium corrosion resistant steel hardened, grounded and stabilized. Two cylinders of equal diameters are attached at the ends. The axes of these two cylinders are mutually parallel to each other and also parallel to and at equal distance from the upper surface of the sine bar. The distance between the axes of the two cylinders is exactly 5 inches or 10 inches, in British system and 100, 200 and 300mm in metric system. Sine bars are more accurate and guaranteed up to 0.01 mm /m of length. There are several forms of sine bars but the one shown in figure is most commonly used. The accuracy of sine bar depends on its constructional features:

- 1) The two rollers must have equal diameter.
- 2) The rollers must be parallel to each other and to the upper face.
- 3) The precise centre distance between the rollers must be known.
- 4) The upper face must have a high degree of flatness

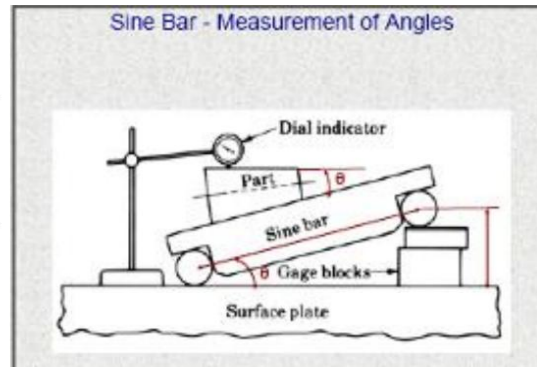
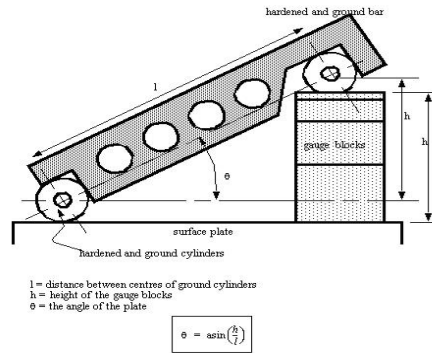

A simple example to illustrate this effect is given below for two extreme cases. In the first case the sine bar is near horizontal, in the second case it is near vertical. Assuming a Sine bar with 150 mm centers, and two angles of $1^{\circ}-30'$ and $88^{\circ}-00'$, and that an 84 piece gauge block set is used.

Bevel Protractor:

It is the simplest instrument for measuring the angle between two faces of a component. It consists of a base plate attached to the main body and an adjustable blade which is attached to a circular plate called turret containing Vernier scale. The adjustable blade is capable of rotating freely about the center of the main scale (graduated around a complete circle from $0-90^{\circ}$, $90^{\circ}-0$ and $0-90^{\circ}$, $90^{\circ}-0$) engraved on the body of the instrument. An acute angle attachment is measured at the top as shown in the figure to measure acute angles. The base of the base plate is made flat so that it could be laid flat upon the work and any type of angle measured. It is capable of measuring from $0-360^{\circ}$.

The Vernier scale has 24 divisions coinciding with 46 main scale divisions (23 on each side). The Vernier scale is graduated to the right and left of zero up to 60 min, each of the 12 graduations representing 5 minutes. Since both the protractor dial and Vernier scale have graduations in both directions from zero, any angle can be measured, but it should be remembered that the Vernier must be read in the same direction from zero as the protractor either right or left. If the zero graduation on the Vernier scale coincides with a graduation on the protractor dial, the reading is in exact degrees, but if some other graduation on the Vernier scale coincides with a protractor graduation, the number of Vernier graduations multiplied by 5 minutes must be added to the number of degrees read between the zeroes on the protractor dial and Vernier scale.

Angular Vernier scales are used on protractors, and are identical in use to linear Vernier scales. The major protractor scales have divisions of 1 degree, and the Vernier scale is divided into 5 minute intervals. One interesting note is that the Vernier scale has two halves, one in the positive direction, and one in the negative direction. If reading from the left division on the main scale, the right Vernier scale should be used. And, when measuring from the right hand division on the major scale, the left Vernier scale should be used.

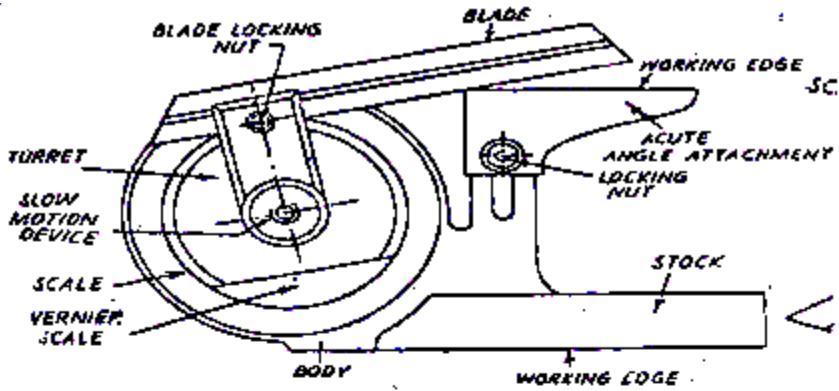

Bevel Protractor

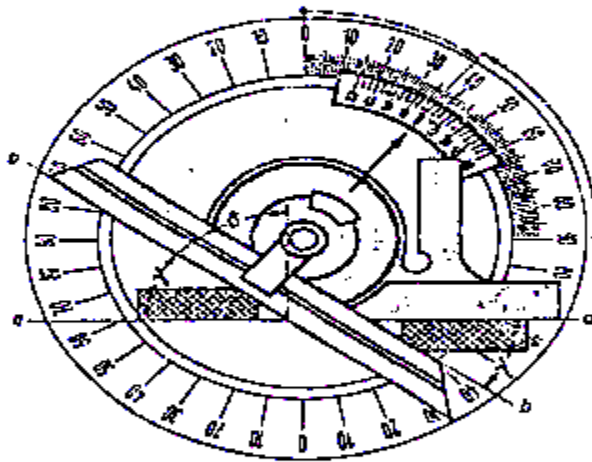

Magnified view of Main Scale

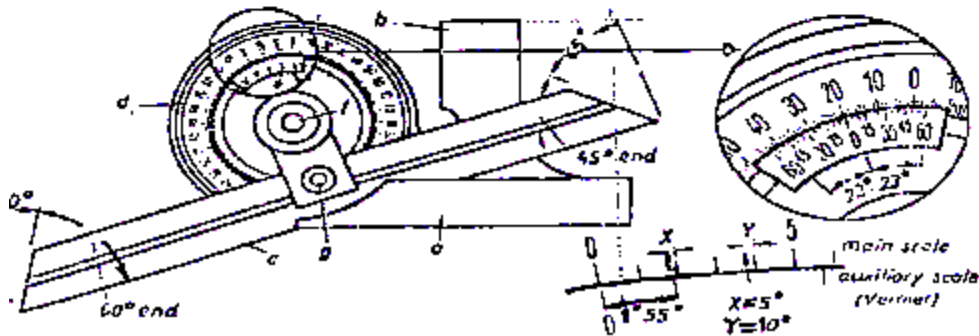

Magnified view of Vernier scale

Gauge Blocks

The purpose of gauge blocks is to provide linear dimensions known to within a given tolerance. The requirements of gauge blocks are the actual size must be known, the faces must be parallel, the surface must have a smooth finish and the surfaces must be flat. Most gauge blocks are made by normal techniques, but the high accuracy is obtained by a process called lapping.

The materials gauge blocks are made from are selected for hardness, temperature stability, corrosion resistance and high quality finish.

Type of gauge blocks rectangular and hoke (square). There are four grades of blocks, reference (AAA) - high tolerance ($\pm 0.00005\text{mm}$ or $0.000002''$), calibration (AA) (tolerance $+0.00010\text{mm}$ to -0.00005mm), inspection (A) (tolerance $+0.00015\text{mm}$ to -0.0005mm) and workshop (B) - low tolerance (tolerance $+0.00025\text{mm}$ to -0.00015mm)

The metric set has 88 gauge blocks (in mm). Most gauge block sets include thin wear blocks that should be included at the ends of a gauge block stack to protect the other gauge blocks.

To assemble a gauge block stack,

1. Remove the gauge blocks required from the protective case.
2. Clean of the oil that they have been coated in using a special cleaner. It is acceptable to handle the blocks; in fact the oil from your hands will help them stick together.
3. One at a time, hold the blocks so that the faces just overlap, push the blocks together, and slide them until the faces overlap together. This will create a vacuum between the blocks that makes them stick together (this process is known as wringing).
4. Make required measurements with the gauge blocks, being careful not to damage the faces
5. Take the blocks apart, and apply the protective coating oil, and return them to their box.

$\leq 0.01\text{mm}$ divisions									
1.001	1.002	1.003	1.004	1.005	1.006	1.007	1.008	1.009	

0.01mm divisions									
1.01	1.02	1.03	1.04	1.05	1.06	1.07	1.08	1.09	1.10
1.11	1.12	1.13	1.14	1.15	1.16	1.17	1.18	1.19	1.20
1.21	1.22	1.23	1.24	1.25	1.26	1.27	1.28	1.29	1.30
1.31	1.32	1.33	1.34	1.35	1.36	1.37	1.38	1.39	1.40
1.41	1.42	1.43	1.44	1.45	1.46	1.47	1.48	1.49	

0.5mm divisions									
0.5	1.0	1.5	2.0	2.5	3.0	3.5	4.0	4.5	5.0
5.5	6.0	6.5	7.0	7.5	8.0	8.5	9.0	9.5	

1cm divisions									
10	20	30	40	50	60	70	80	90	

two 2mm wear blocks									
---------------------	--	--	--	--	--	--	--	--	--

When using gauge blocks, minimize the number used. Each block will have tolerance errors, and as the stack of blocks becomes larger, so does the error. Do not leave gauge blocks wrung together for long periods of time.

Checking of unknown angles:

Many a time, angle of a component to be checked is unknown. In such a case, it is necessary to first find the angle approximately with the help of a bevel protractor. Let the angle be θ . Then the sine bar is set at an angle θ and clamped to an angle plate. Next, the work is placed on sine bar and clamped to angle plate as shown in below figure and dial indicator is set at one end of the work and moved to the other, and deviation is noted. Again slip gauges are so adjusted that dial indicator reads zero across work surface.

If deviation noted down by the dial indicator is δh over a length of L of work, then height of slip gauges by which it should be adjusted is equal to $\delta h \times L/L^1$.

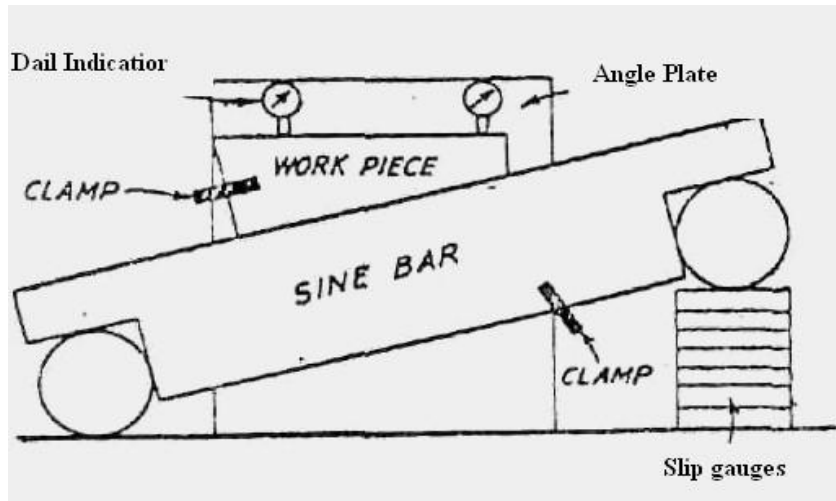

Angle measurement by bevel protractor

- 1) The base of the bevel protractor is placed on the top horizontal surface of the top component
- 2) Blade locking nut is loosened and by rotating the blade about the centre of the main scale, the working edge of the blade is made to coincide with the inclined surface of the component
- 3) Blade is locked in that position by tightening the nut
- 4) Vernier scale division coinciding with main scale division is noted.

Inclination of the surface with respect to horizontal is calculated as follows

$$\text{Angular reading} = \text{MSD} + (\text{vernier scale division} * \text{L.C})$$

Tabular Column

Sine Bar

S.No	Height of gauge blocks(h) in mm	Sine bar length(l) in mm	$\theta = \text{Sin}^{-1}(h/l)$

Bevel protractor

S.No	MSR (a) in °	VC (n)	$b = n * L.C$ in '	$\theta = a + b$

PROCEDURE:

Angular Measurement by Sine Bar

1. This sine bar is made to rest on the surface plate with rollers contacting the datum
2. Place the component on sine bar and lock in position
3. Lift one end (roller) of the sine bar and place a pack of gauge blocks underneath the roller
4. With the help of dial indicator make the surface flat by using suitable set of gauge blocks.
5. Note down the height of gauge blocks and determine the angle of the specimen.

Precautions

1. The sine bar should not be used for angles greater than 45 degrees because any possible error in construction is associated at this limit.
2. At larger angles, the sine bar is susceptible to errors in the length of the sine bar, as well as in the height of the gauge blocks.
3. When using a Sine bar, the height setting is limited by the gauge block divisions available. This results in an error that may be negligible or in some cases quite significant.
4. When a reference for a non-square angle is required, a sine bar can be used.
5. Accuracy of sine bar should be ensured.
6. Angle of instrument must coincide with the angular scale
7. Gripped the instrument to the measuring face exactly

Space For Calculations

RESULT & CONCLUSIONS:

- The taper angle of given component is measured using sine bar
- The angles of given component is measured using bevel protractor and are tabulated

VIVA QUESTIONS:

- Up to which angle sine bars can measure the angles?
- What is sine centre?
- Upto which inclination sine centres can be used?
- Why do we use Sine bars to find angles?
- What are the sources of errors in sine bars?
- What is the difference between slip gauge and pitch gauge
- List the applications of bevel protractor.
- What are the sources of errors in sine bars?
- Principle of Sine bar?
- Principle optical bevel protractor

EXPERIMENT - 04

MEASUREMENT WITH DIAL INDICATOR /DIAL BORE GAUGE/SNAP GAUGE

AIM:

To find Ovality of cylindrical bore of a given component using dial bore gauge.

APPARATUS:

- Inside micrometer
- Dial test indicator
- Bore gauge,
- Vernier calipers
- Specimen

THEORY:

Dial bore indicator consists of dial test indicator, bore gauge and set of measuring heads and space washers. Determination of Ovality means to decide that the given hollow circular specimen is perfectly round or not. This is usually measured by dial bore gauge.

Specification:

- a) Inside micrometer: Range ----mm, Least count = ---mm.
- b) Dial bore indicator: Range -----mm, Least count =---- mm.
- c) Dial Indicator : Range --- mm, Least count =---- mm.

Dial test indicator:

It is a small indicating device used for linear measurements. It uses mechanical means such as gears and pinions or levers for magnification. It is the simplest type of mechanical comparator. It measures the displacement of its plunger or a stylus on a circular dial by means of a rotating pointer. By mounting the dial test indicator on bore gauge it can be used for determining errors in geometrical forms like Ovality, taper etc.

Dial Indicator converts linear displacement into a radial movement to measure over a small range of movement for the plunger. The radial arm magnification principle is used here. These indicators are prone to errors caused by errors that are magnified through the gear train. Springs can be used to take up any play/backlash in the rack and pinion to reduce these errors. The gears are small, but friction can result in sticking, thus reducing accuracy. A spring is used on the rack to return the plunger after depression. The problems mentioned earlier will result in errors in these instruments. If the dial indicator is used to approach a dimension from two different sides, it will experience a form of mechanical hysteresis that will bias the readings. An example of this effect is given below.

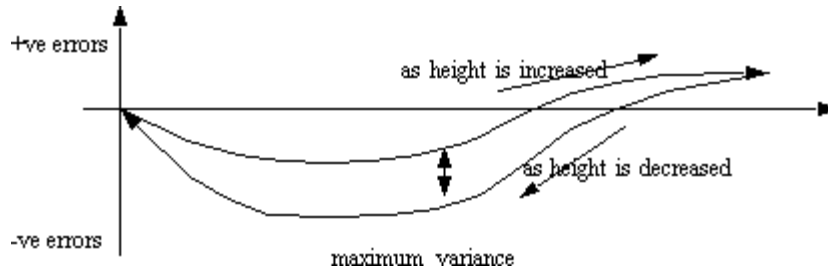

In the graph shown, as the dial indicator is raised in height (taking care not to change direction), the errors are traced by the top curve. As the height of the dial indicator is decreased, the bottom curve is traced. This can be observed using gauge blocks as the known heights to compare the readings against. The causes of this hysteresis are bending strain, inertia, friction, and play in the instrument.

Applications include,

- centering work pieces to machine tool spindles
- offsetting lathe tailstocks
- aligning a vise on a milling machine
- checking dimensions

These indicators can be somewhat crude for accurate measurements; comparators have a higher degree of sensitivity.

Bore gauge:

It consists of one fixed measuring head and one movable measuring head. The horizontal movement of measuring head is transmitted to dial indicator by push rod through a spring actuated hinged member. Different lengths of measuring heads are provided to check different sizes of bores.

The reading that is obtained from the gauge is indicated by dial indicator. The reading in dial indicator is multiplied with its least count to get actual deviation w.r.t the nominal diameter of the bore. The actual size of the bore can be calculated by subtracting the deviation from the nominal diameter. To check circularity of bore of given specimen, it is required to take at least four readings at four different places of the bore.

Inference: The size of the bore is minimum ---- mm & maximum --- mm.

Troubleshooting :

- Calibration is done by using standards
- Error adjust
Recheck after error adjustment

Dial Indicator

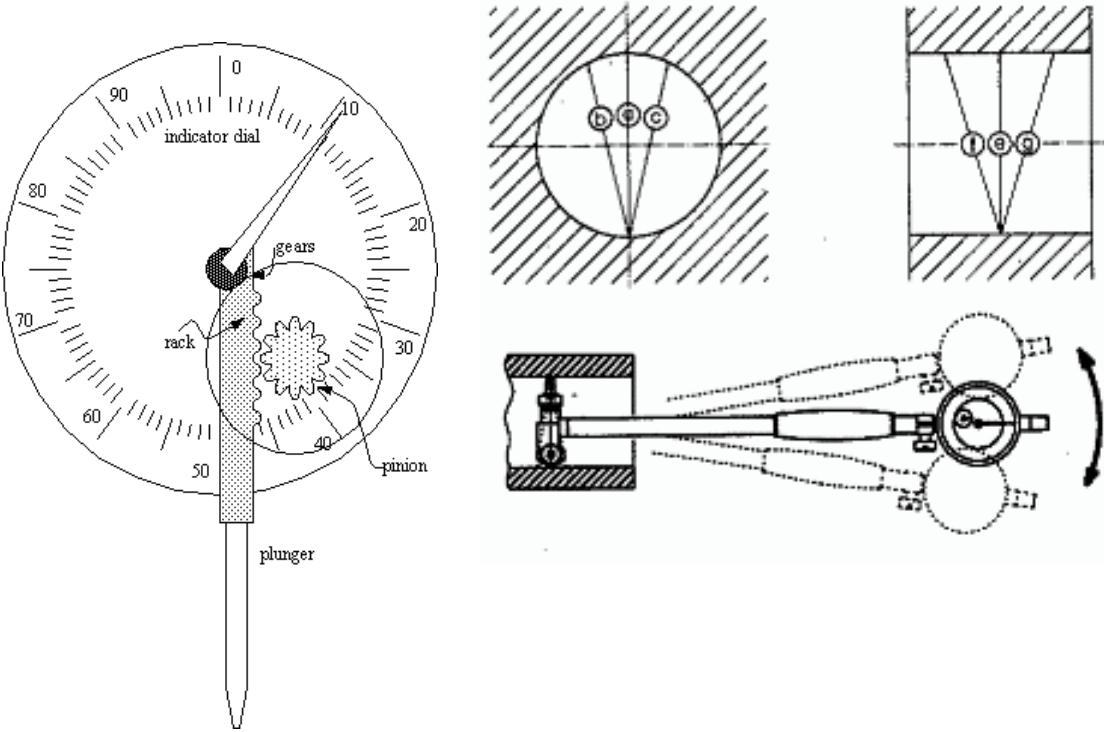

Bore Gauge

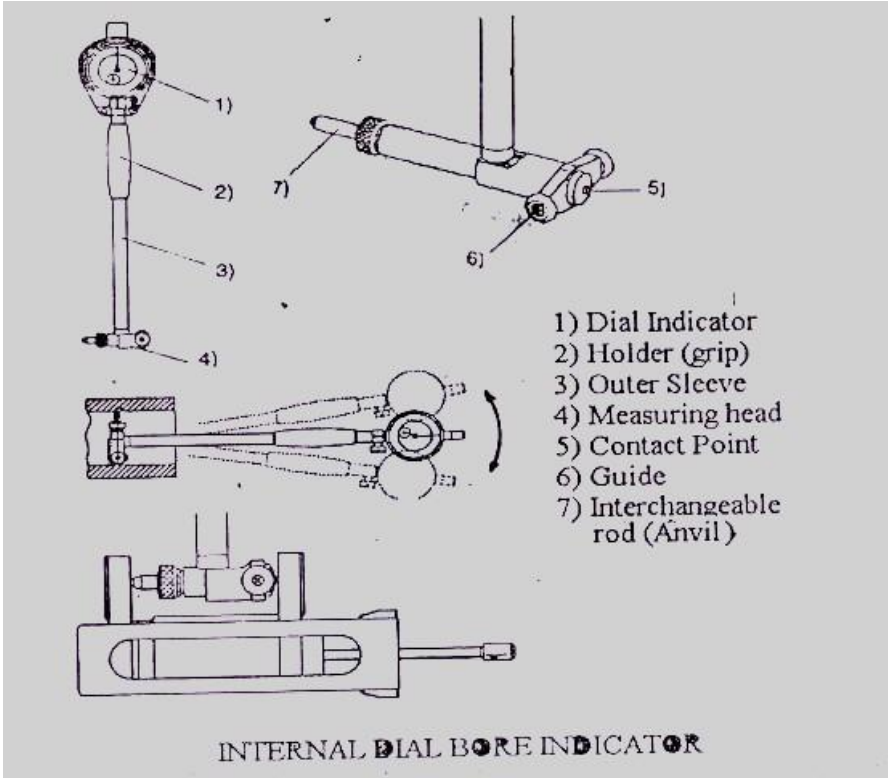

Principle: Dial bore indicator works on comparator principle.

PROCEDURE:

1. Mount the dial indicator on the bore gauge.
2. Measure the approximate diameter of the hole of the given specimen using vernier calipers
3. Select the appropriate measuring head available from the set based on the reading obtained from the vernier calipers
4. Fix the selected measuring head in the instrument
5. Now divide the given circular specimens bore into no. of equal parts
6. Measure the diameters of the hole by dial bore gauge at different divisions and note down the reading of the dial indicator.
7. Subtract the dial indicator readings from the nominal diameter of the bore to get the actual size.
8. All the readings obtained by above step are plotted on the graph for checking ovality.
9. The deviations obtained between nominal diameter and actual diameters are considered as Ovality of the given specimen.

Tabular Column

S.No	Division no	Dial indicator reading (a)	Space length mm	Deviation $b=L.C*a$, (mm)	Actual diameter (mm)
1	1-1 ¹	38	1	0.38	$24+1-0.38=24.62$

Precautions:

1. Select the correct size of measuring head based on the vernier caliper readings. Add space washers if necessary.
2. Do not disassemble the instrument.
3. Do not bump any part of the instrument.
4. After use, clean the interchangeable rod/ washer apply a coat of anti-corrosive oil to them and store them in their containers.
5. Avoid parallax errors while noting the values of dial indicator
6. The measuring head should be placed at right angles to the axis of the bore while taking the readings
7. Set the dial indicator reading to zero before taking measurement.

Space For Calculations

RESULT & CONCLUSIONS:

The Ovality of given hollow specimen is obtained in the graph sheet.

VIVA QUESTIONS:

- What are the precautions required during use of inside micrometer & dial Bore indicator?
- Which one is more precise when compared to inside micrometer & dial bore Indicator?
- What are the applications of inside micrometer & dial bore indicator?
- How do you find the least count of inside micrometer?
- What are the other instruments for measuring bores?

EXPERIMENT - 05

MEASUREMENT OF ROUNDNESS ERRORS WITH BENCH CENTERS, V- BLOCK AND DIAL GAUGE

AIM:

Measurement of roundness given specimen by using V-Block and Dial Gauge

APPARATUS:

- V-Block
- Dial indicator

THEORY:

Measurement of Roundness using V-Block Method

Out of roundness of mechanical parts could be due to poor bearings in the lathe grinding wheel spindle, or deflection of the workpiece as the tool is brought to bear on it. Shafts which are ground between centers or deflection of the shaft. A round bar or ring type part held in a chuck for grinding or turning is compressed at the points of contact giving rise to stresses in the material. When it is removed from the chuck the stress in the material will be released, giving rise to lobes. Drawn or extruded parts takes their shapes from the dies and roundness checks on the parts cannot only any imperfections which cause scoring along the surface. A worn tool or one not set correctly could produce chatter marks. Generally a part is said to be round in a specific cross section if there exists within that section of a point (centre) from which all other on the periphery are equidistant. The cross section is therefore a perfect circle. The out of roundness is specified as the difference in distance of points on the periphery from the centre. But to specify out of roundness of an irregular profile it is possible if we can find a centre from which to make the measurements. So finding a centre of the part is an important part of roundness testing. There are many methods of testing roundness of a part.

1. V- block method or three-point method.
2. Bench centre method.
3. Stylus method turntable or pick up rotation method.

The following are the essential features, which need to be incorporated in a roundness-measuring instrument. Since roundness is normally measured by rotation either the part itself can be rotated against a fixed measuring device, or the measuring device can be rotated around the stationary part. The axis of rotation must be independent of the part being measured because when the part itself is used as one of the bearing surfaces for rotation, the irregularities on the surface cause the whole part to move up and down make simple & accurate measurements of roundness impossible.

Type of measuring devices. In bench type measurements a simple dial indicator is adequate but in an instrument capable of very accurate rotation, a non-mechanical gauge is employed. This can be in the form of an electrical transducer (pick – up) **Indicator**. Any measuring device must have an indicator from which the measurements can be read. Roundness tester sometimes have a meter but is gives a fluctuating reading a used for setting up only. As such a graph is provided result to get more information about the roundness this datum is the axis of rotation of the

spindle. Roundness measuring instruments are of two basic types. In one (Rotation pick up) type the part is stationary and pick up revolves about it and in other type (Turntable type) the workpiece rotates.

Rotating pick up type In this type the spindle has only to carry the light, constant load of pickup. High accuracy is therefore can be obtained.

The worktable not being part of the measuring system, can be of substantial construction, so the weight of the part is not a limitation on measuring capacity many large parts (cylinder blocks) of asymmetrical shape, with the centre of the bore or surface to be measured off set from the centre of gravity long shafts and crankshaft can also be accommodated.

Turntable type Since the pick-up is not associated with the spindle this type of instrument is more easily adapted for roundness measurements, such as concentricity and alignment. It is easier in positioning the pick up to reach into slots or to underside of shoulders without having to use long or cranked stylus arms. The weight of the turntable and the part being tested has to be supported by the spindle bearing; this limits the weight of parts that can be measured. It also limits the offset of the part that can be accommodated.

V-Block Method This method is the simplest and most useful in determining the circularity errors and number of lobes. When a rounded part held in chuck is compressed at the point of contact. Even when the part is turned or ground to perfect round on the machining, after it is removed from the chuck, the stress on the metal gets relieved, cause the lobes. The number of lobes can be varied from two to hundreds about the circumference of the cross section. Two, three, five, seven and nine lobes are common results of machining processes.

PROCEDURE:

1. The specimen is first cleaned and marked 12 points @ 30° each on the face of the specimen.
2. A V-block is placed on the surface plate and the specimen is placed upon it.
3. A dial indicator with a stand is rest against the surface of the job.
4. The dial indicator is set just above the specimen so that it touches the workpiece at the axis of the specimen.
5. Specimen is then rotated and dial reading are taken at each marking.
6. For plotting the polar graph, a suitable scale is chosen depending upon the maximum value of the dial indicator.
7. draw a circle of dia nearly 4 times the max reading of the dial indicator. Inside this circle, draw another circle nearly half of the max value of outer circle. Now divide this circle into 12 points to indicate the actual shape of the workpiece.
8. Now the values are plotted in radial (clockwise) direction taking the smaller circle as the reference circle in order that both the positive & negative readings are plotted

Space For Calculations

RESULT & CONCLUSIONS:

VIVA QUESTIONS:

- What is the use of V-Blocks?
- What is the bearing area of V-Blocks?
- Which V block is used for checking triangle effect?
- What is the material of the bench center's base?
- What is roundness?
- What is squareness?
- For cylindrical elements which parameters are more important?
- Explain the working principle of dial indicator?

EXPERIMENT - 06

MEASUREMENT OF LINEAR AND ANGULAR DIMENSIONS WITH TOOL MAKER'S MICROSCOPE

AIM:

To Measure the thickness, taper, radius of curvature, thread element etc.

APPARATUS:

- Tool Maker's Microscope

THEORY:

Measurement of pitch or pitch errors (Tool Maker's microscope)

It is very necessary to measure the pitch of, say, a tap used to produce a 20 mm ISO coarse thread. The measurement must be made in such a way that other features or dimensions e.g., diameter and thread angle do not influence the results in any way, and in general two methods are employed:

1. Optical projection
2. Pitch measuring machine
 - a) Optical projection. A **toolmaker's microscope** uses the principle of optical projection. The screw is set between centers on the microscope table, care being taken to ensure that the table is rotated by an angular amount equivalent to the helix angle of the thread. With a master thread file mounted in the projection head, a sharp image of the thread is projected on the screen to match the master profile, and reading is taken on the micrometer dials controlling the movement of the table along the screw axis.
 - b) The table is now traversed until the magnified image of the next thread matches the master profile, and the reading taken at the micrometer indexing dial.
 - c) The pitch is now the distance traversed by the table, and if the pitch is correct the amount of traverse will equal the stated value for the pitch. The principle is simply illustrated in the figure below and it may be appreciated that both depth of thread and flank angles may also be checked or measured using the principle of projection.

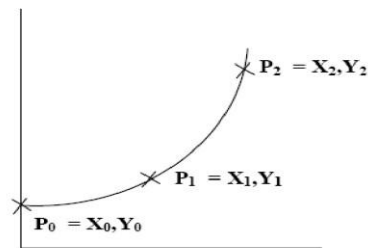

$$P_1 = P_1 - P_0 \quad (\text{i.e., } X_1 - X_0, \quad Y_1 - Y_0)$$

$$P_2 = P_2 - P_0 \quad (\text{i.e., } X_2 - X_0, \quad Y_2 - Y_0)$$

$$R = \frac{\sqrt{(X_1^2 + Y_1^2)(X_2^2 + Y_2^2)}[(X_1 - X_2)^2 + (Y_1 - Y_2)^2]}{2(X_1Y_2 - X_2Y_1)}$$

Radius Measurement by 3 point Method

Tool Makers Microscope

In contour illumination light passes through the object to produce dark image of the image contour. By this source we can easily measure the external dimension of the object.

In a surface illumination light reflects over the object and again reflect back to the screen. Here we can see the surface texture of the object. This is also very useful for comparison.

The eyepiece has cross hairlines marked on its centre which represents the X and Y co – ordinates with respect to the movement of micrometer stage. Measurements are taken with one edge of the object coinciding with the respective cross hairline and then the micrometer is rotated to bring the other edge of the object to coincide with the same cross hairline. When point contact method is needed the axis (intersection point) of the co – ordinates is selected. (Eg: Circle, radius by 3 points method and Angles by 4 point method or when used with Data processor). The protractor eyepiece has a graduated scale above the main eyepiece tube, which can be rotated by a knob beneath the eyepiece housing for angular measurement through 360°. On the smaller eyepiece minute Vernier scale is marked with 1' accuracy. By rotating the protractor we can set the cross hairline a shore Fogbows I D parallel to the object side and get the differential readings. The work will be held on micrometer stage and focused on the screen by means of vertical movement of stage until a sharp image of the object is obtained.

Tool maker's microscope:-

Tool maker's microscope is a versatile instrument that measures by optical means with no pressure being involved it is thus a very useful instrument for making measurements on small and delicate parts. The tool maker's microscope is designed for the following measurements; measurements on parts of complex form for example, the profile of external thread as well as for the tools, templates and gauges, measuring centre to centre distance of holes in any plane and other wide variety of linear measurements and accurate angular measurements.

A tool maker's microscope is as shown in fig. The optical head can be moved up or down the vertical column and can be clamped at any height by means of clamping screws. The table which is mounted on the base of the instrument can be moved in two mutually perpendicular horizontal directions (longitudinal and lateral) by means of accurate micromeres screws having thimble scale and venires.

A ray of light from light source is reflected by mirror through 90. It is then passes through a transparent glass plate (on which flat parts may be placed). A shadow image of the outline or contour of the workpiece passes through the objective of the optical head and is projected by a system of three prisms to ground glass screen. Observations are made through an eyepiece. Measurements are made by means of cross lines engraved on the ground glass screen. The screen can be rotated through 360 the angle of rotation is read through an auxiliary eyepiece.

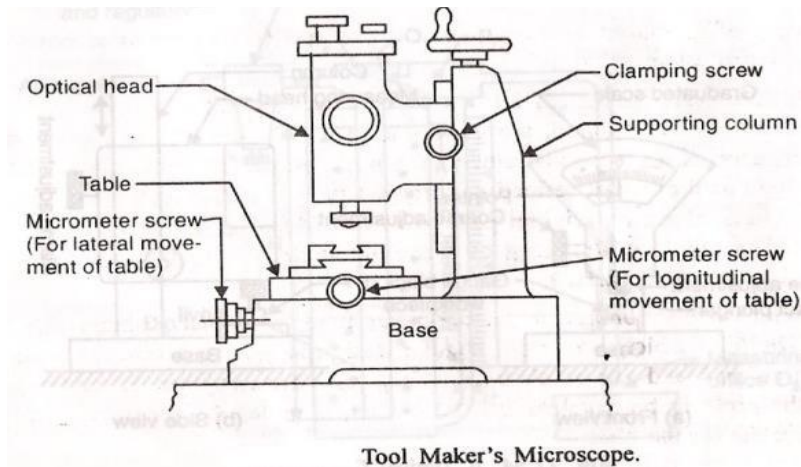

PROCEDURE:

The use of - tool maker's microscope for the taking the various measurements is explained below-

- 1) For taking linear measurements, the work piece is placed over the table. The microscope is focused and one end of the work piece is made to coincide with cross line in the microscope (by operating micrometer screws). The table is again moved until the other end of the workpiece coincide with the cross line on the screen and the final reading taken. From the final reading, the desired measurement can be taken.
- 2) To measure the screw pitch, the screw is mounted on the table. The microscope is focused (by adjusting the height of the optical head) until a sharp image of the projected contour of the screw is seen of the ground glass screen. The contour is set so that some point on the contour coincides with the cross line on the screen. The reading on the thimble of the longitudinal micrometer screw is noted. Then the table is moved by the same screw until a corresponding point on the contour (profile) of the next thread coincides with the cross line. The reading is again noted and the difference in two readings gives the screw pitch.
- 3) To determine pitch diameter the lateral movement to the table is given
- 4) To determine the thread angle, the screen is rotated until a line on the angle of screen rotation is noted. The screen is further rotated until the same line coincides with the other flank of the threads. The angle of thread on the screen will be difference in two angular readings.

Different types of graduated and engraved screens and corresponding eyepiece are used for measuring different elements.

Types of Measurements:

- Thickness = 2 point / line reference.
- Diameter / radius = 3 point / point reference.
- Thread measurement = Major diameter, Minor diameter, Pitch and Angle.
- Angle measurement =
Using point measurement system.

Precaution:-

- 1) Obtain clean picture of cross line and the cross thread seen through the eyepiece
- 2) For angular measurements lines must remain parallel to flank edge to the tooth

Space For Calculations

RESULT & CONCLUSIONS:

- 1) External diameter = $R_2 - R_1 = \text{-----mm.}$
- 2) Internal diameter = $R_2 - R_1 = \text{-----mm.}$
- 3) Pitch of threads = $R_2 - R_1 = \text{----- mm.}$
- 4) Threads angle = $R_2 - R_1 = \text{----- mm.}$

VIVA QUESTIONS:

- What is meant by the tool maker's microscope?
- What is the light used in a tool maker's microscope?
- Define – Pitch?
- What are the causes of pitch error?
- Define the magnification factor of a tool maker's microscope?
- What are the advantages of a tool maker's microscope?
- What are the various characteristics that you would measure in a screw thread?
- What are the instruments that are required for measuring screw thread?

EXPERIMENT - 07 SURFACE ROUGHNESS TESTING

AIM:

To determine surface roughness of a given specimen.

APPARATUS:

- Surface roughness tester
- Specimen

THEORY:

When measuring roughness of part surface, the pickup is placed on the surface of the part and then tracing the surface at constant rate. The pickup acquires the surface roughness by the sharp stylus in pickup. The roughness causes displacement of pickup which results in change of inductive value of induction coils thus generate analogue signal which is in proportion to surface roughness at output end of phase-sensitive rectifier. This signal enters data collection system after amplification and level conversion. After that, those collected data are processed with digital filtering and parameter calculation by DSP chip and the measuring result can be read on LCD, printed through printer and communicated with PC.

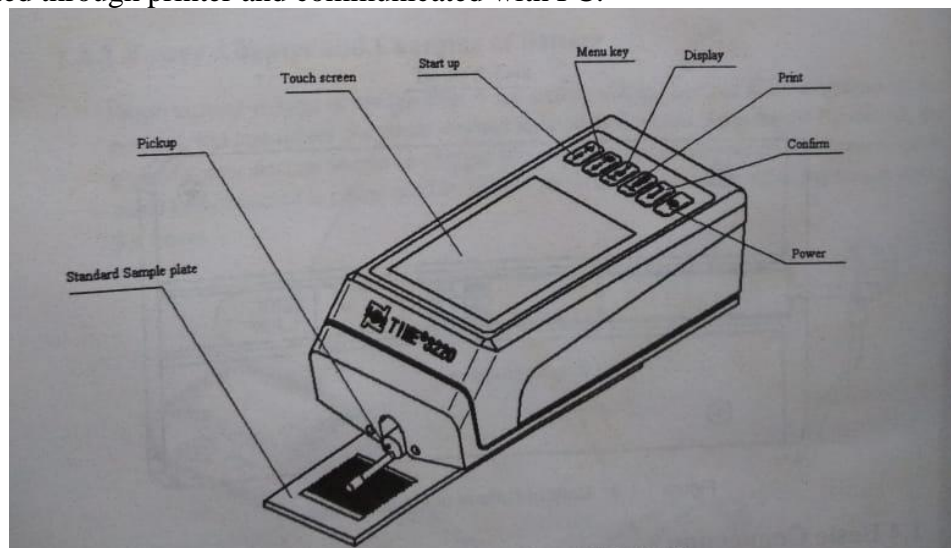

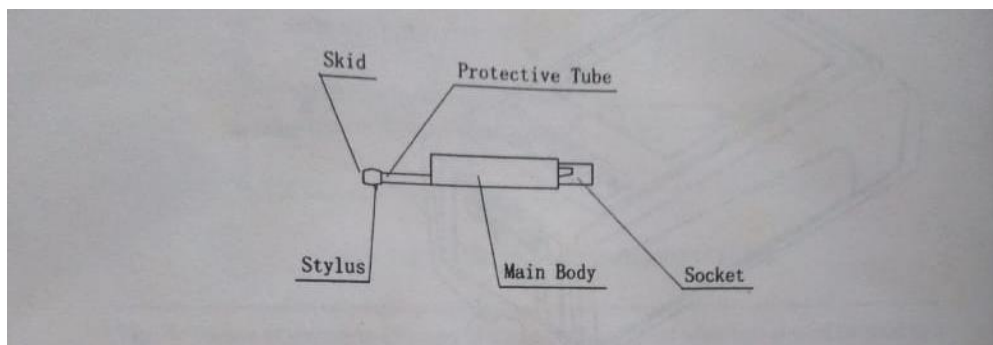

Surface Roughness Tester



Pickup

PROCEDURE:

- Switch on select settings
 - Display Range
 - Take all value mentioned below
- Select (Ra) close the tab Exit -
 - click the button  then take the readings
- Select (Rp) close the tab Exit
 - click the button  then take the readings
- Follow the above procedure for all values mentioned

Tabular Column

S.No	Specimen Details	Ra	Rp	Rv	Rt	Rz	Rq	Rsk	Rku	Rc	RSm	Rmr(c)	Rmr	Rz1max	Rδc	RΔq

Precautions:

- Switch-on to check if battery voltage is normal
- Clear the surface of part to be measured
- Refer to Fig2-1 and 2-2 to place the instrument correctly stably and reliably on the surface to be measured
- refer to fig 2-3 trace of the pickup must be vertical to the direction of process line of the measured surface

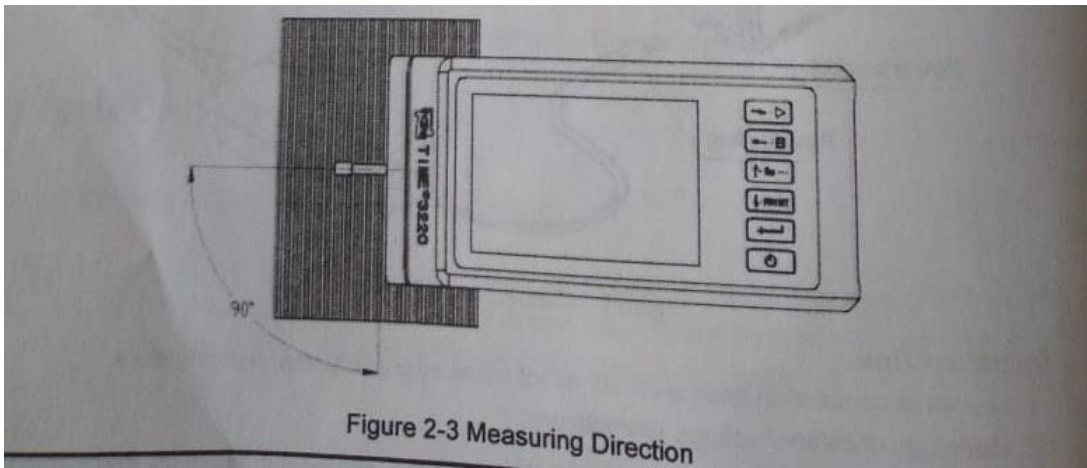
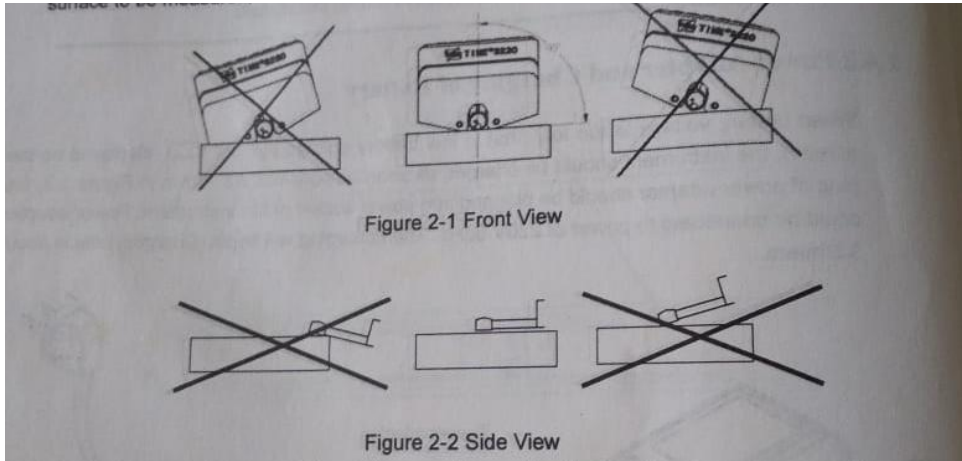

Space For Calculations

RESULT & CONCLUSIONS:

VIVA QUESTIONS:

- What is meant by surface roughness?
- Which type of the inspection is the best for the examination of surface finish
- Up to which limit the irregularities can be detected with touch inspection of a surface
- What is the first order of surface irregularity?
- What is ten point height method?

EXPERIMENT - 08

MEASUREMENT ANGLE USING GEAR TOOTH VERNIER

AIM:

To measure gear tooth thickness and addendum by using gear tooth Vernier

APPARATUS:

- Gear tooth vernier callipers
- Spur gear

THEORY:

Terminology of gear tooth:

Pitch surface: The surface of the imaginary rolling cylinder (cone, etc.) that the toothed gear may be considered to replace.

- **Pitch circle:** A right section of the pitch surface.
- **Addendum circle:** A circle bounding the ends of the teeth, in the right section of the gear.
- **Root (or dedendum) circle:** The circle bounding the spaces between the teeth, in the right section of the gear.
- **Addendum:** The radial distance between the pitch circle and the addendum circle.
- **Dedendum:** The radial distance between the pitch circle and the root circle.
- **Clearance:** The difference between the dedendum of one gear and the addendum of the mating gear.
- **Face of a tooth:** That part of the tooth surface lying outside the pitch surface.
- **Flank of a tooth:** The part of the tooth surface lying inside the pitch surface.
- **Circular thickness** (also called the **tooth thickness**) : The thickness of the tooth measured on the pitch circle. It is the length of an arc and not the length of a straight line.
- **Tooth space:** The distance between adjacent teeth measured on the pitch circle.
- **Backlash:** The difference between the circle thickness of one gear and the tooth space of the mating gear.
- **Circular pitch** p : The width of a tooth and a space, measured on the pitch circle.
- **Diametric pitch** P : The number of teeth of a gear per inch of its pitch diameter. A toothed gear must have an integral number of teeth. The circular pitch, therefore, equals the pitch circumference divided by the number of teeth. The diametric pitch is, by definition, the number of teeth divided by the pitch diameter. That is,

$$p = \frac{\pi D}{N}$$

and

$$P = \frac{N}{D}$$

Hence

$$pP = \pi$$

where

p = circular pitch

P = diametric pitch

N = number of teeth

D = pitch diameter

That is, the product of the diametric pitch and the circular pitch equals π

- **Module** m : Pitch diameter divided by number of teeth. The pitch diameter is usually specified in inches or millimeters; in the former case the module is the inverse of diametric pitch.
- **Fillet**: The small radius that connects the profile of a tooth to the root circle.
- **Pinion**: The smaller of any pair of mating gears. The larger of the pair is called simply the gear.
- **Velocity ratio**: The ratio of the number of revolutions of the driving (or input) gear to the number of revolutions of the driven (or output) gear, in a unit of time.
- **Pitch point**: The point of tangency of the pitch circles of a pair of mating gears.
- **Common tangent**: The line tangent to the pitch circle at the pitch point.
- **Line of action**: A line normal to a pair of mating tooth profiles at their point of contact.
- **Path of contact**: The path traced by the contact point of a pair of tooth profiles.
- **Pressure angle** π : The angle between the common normal at the point of tooth contact and the common tangent to the pitch circles. It is also the angle between the line of action and the common tangent.
- **Base circle** : An imaginary circle used in involutes gearing to generate the involutes that form the tooth profiles.

Specifications:

- a) Gear Tooth vernier calipers – range 0-150 mm , LC = 0.02mm
- b) Spur gear size = Standard size
- c) Vernier calipers - range 0-150 mm, LC = 0.02mm

Measurement of tooth thickness:

The permissible error of the tolerance on thickness of tooth is the variation of actual thickness of tooth from its theoretical value. The tooth thickness is generally measured at pitch circle and is therefore the pitch line thickness of tooth i.e length of an arc which is difficult to measure directly. In most of the cases, it is sufficient to measure the chordal thickness i.e the chord joining the intersection of the tooth profile with the pitch circle. Also the difference between chordal tooth thickness and circular tooth thickness is very small for gear of small pitch. The thickness measurement is the most important measurement because most of the gears manufactured may not undergo checking of all parameters, but thickness measurement is a must for all gears.

The tooth thickness can be very conveniently measured by a gear tooth vernier. Since the gear tooth thickness vary from the tip to the base circle of the tooth the instrument must be capable of measuring the tooth thickness at a specified position on the tooth. Further this is possible only when there is some arrangement to fix that position where the measurement is to be taken. The

gear tooth vernier has two vernier scales and they are set for the width (w) of the tooth and the depth (d) from the top, at

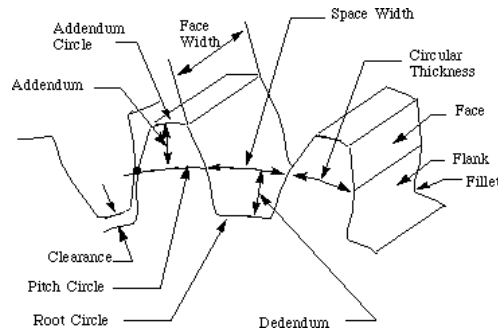

Considering one gear tooth, the theoretical values of 'w' and 'd' can be found which may be verified by the instrument .

From figure, chordal thickness = $w = AB = 2 \cdot AD$

Angle $AOD = \theta = 360^\circ/4N$ where N is the number of teeth.

$$w = 2 AD = 2 AO \sin \theta = 2R \sin (360/4N)$$

Where R = pitch circle radius = $Nm/2$

Module $m = PCD/N$

$$\begin{aligned} \text{Chordal thickness } w &= 2(Nm/2) \sin (360/4N) \\ &= Nm \sin 90/N \end{aligned}$$

Also from figure,

$$d = OC - OD$$

$$\begin{aligned} \text{But } OC &= OE + \text{addendum} \\ &= R + m \\ &= Nm/2 + m \end{aligned}$$

$$\begin{aligned} \text{And } OD &= R \cos \theta \\ &= Nm/2 \cos 90/N \end{aligned}$$

Therefore $d = Nm/2 + m - Nm/2 \cos (90/N)$

$$\text{Chordal addendum } = d = Nm/2[1 + 2/N - \cos (90/N)]$$

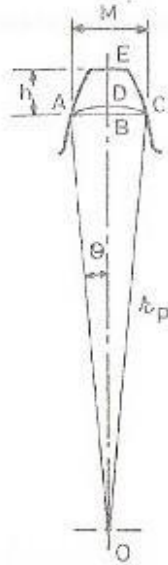

Tooth thickness at pitch line

the addendum ED .

Referring to Fig. 12.19,

$$M = 2AB$$

In triangle ABO , $AO = r_p = \frac{d_p}{2} = \frac{mT}{2}$

$$\text{Also } \theta = \frac{360^\circ}{4T}$$

$$= \frac{90}{T}$$

$$\sin \theta = \frac{AB}{AO}$$

$$AB = AO \sin \theta$$

$$= \frac{mT}{2} \sin \left(\frac{90}{T} \right)$$

$$\text{But } M = 2AB$$

$$M = mT \sin \left(\frac{90}{T} \right)$$

Again from Fig.

$$h = OE - OB$$

$$\text{and } OE = r_p + \text{Addendum}$$

$$= \frac{mT}{2} + m$$

$$\text{and } OB = OA \cos \theta$$

$$= \frac{mT}{2} \cos \left(\frac{90}{T} \right)$$

$$\therefore h = \left(\frac{mT}{2} + m \right) - \frac{mT}{2} \cos \left(\frac{90}{T} \right)$$

$$h = \frac{mT}{2} \left[1 + \frac{2}{T} - \cos \left(\frac{90}{T} \right) \right]$$

$$\text{and from (1) } M = mT \sin \left(\frac{90}{T} \right)$$

Also the actual thickness i.e. arc length (M') can be determined as follows

$$M' = 2 \times \left(\frac{d_p}{2} \times \theta \right)$$

$$= d_p \theta$$

$$= mT \sin^{-1} \left(\frac{90}{T} \right)$$

$$\text{Since } M = mT \sin \left(\frac{90}{T} \right)$$

Eliminating mT from (12.3) and (12.4), we get

$$M = \frac{M'}{\sin^{-1} \left(\frac{90}{T} \right)} \times \sin \left(\frac{90}{T} \right)$$

$$\text{Hence } M' = \frac{M \sin^{-1} (90/T)}{\sin (90/T)}$$

PROCEDURE:

1. Count the number of teeth (N) on the gear.
2. Measure the outside diameter (D_0) of the gear.
3. Calculate the module from the relation $m = D_0 / (N+2)$
4. Calculate the value of chordal addendum (d).
5. Set the gear tooth vernier callipers from depth 'd' and measure 'w' i.e. chordal thickness of tooth.
6. Repeat the measurement on other teeth and determine an average value.

Tabular Column

Gear 1 –keep 'd' at constant value

S.No	Main Scale Reading(a) mm	Least Count (b) mm	Vernier coincident(c) mm	Total measurement $a + (b*c)$ mm

Gear 2 –keep 'w' at constant value

S.No	Main Scale Reading(a) mm	Least Count (b) mm	Vernier coincident(c) mm	Total measurement $a + (b*c)$ mm

Inferences:

Troubleshooting:

- i) Any worn out parts are there replacing with new one.
- ii) Calibrate the instrument with standard slip gauges.

Precautions:

- i) Don't press the jaws to tight.
- ii) See the reading without parallax error

Space For Calculations

RESULT & CONCLUSIONS:

The theoretical value of gear tooth thickness is slightly differs from the measured value due to the manufacturing inaccuracies.

VIVA QUESTIONS:

- Define various elements of a gear?
- What is Chordal addendum?
- What is chordal thickness of gear tooth
- What are the various parts of gear tooth Vernier?
- Differentiate gear tooth Vernier from ordinary Vernier?
- What are the different types of gears?
- What are the various tests conducted on gears?
- What is the other parameter to be measured in gear by using other testing equipment?
- What is rolling gear test?
- What are the various quantitative tests on gears?

PART-B
MACHINING OPERATIONS &
METAL CUTTING LAB

EXPERIMENT - 09

STEP TURNING, TAPER TURNING & KNURLING

AIM:

To perform step turning, taper turning & knurling operation on lathe.

APPARATUS:

Machinery or Tools Required:

- Lathe
- Steel rule
- Outside callipers
- High speed steel tool bit
- Knurling tool
- Chuck key
- Tool post with key

Material Specification:

- Mild steel rod of 25mm diameter 100mm length.

THEORY:

Lathe removes undesired material from a rotating work piece in the form of chips with the help of a tool which is traversed across the work and can be fed deep in work. The tool material should be harder than the work piece and the later help securely and rigidly on the machine. The tool may be given linear motion in any direction. A lathe is used principally to produce cylindrical surfaces and plane surfaces, at right angles to the axis of rotation. It can also produce tapers and bellows etc.

A lathe basically consists of a bed to provide support, a head stock, a cross slide to traverse the tool, a tool post mounted on the cross slide. The spindle is driven by a motor through a gear box to obtain a range of speeds. The carriage moves over the bed guide ways parallel to the work piece and the cross slide provides the transverse motion. A feed shaft and lead screw are also provided to power the carriage and for cutting the threads respectively.

Specification of Lathe:

Length of bed: _____mm

Width of bed: _____mm

Height of centres: _____mm

Admit between centres: _____mm

Lead screw pitch: _____mm

Power of the motor: _____H.P.

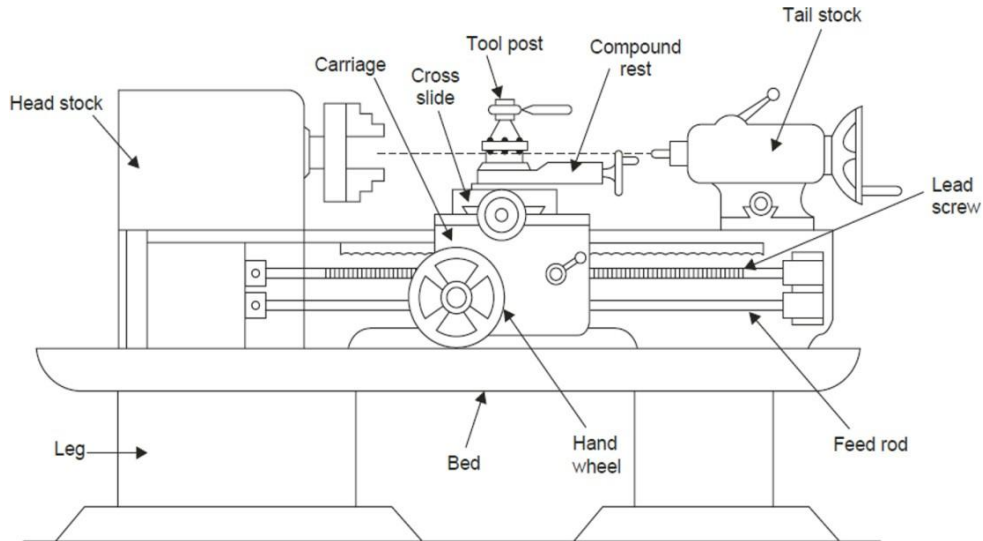

PROCEDURE:

Sequence of Operations

- Facing
 - Plain Turning
 - Step Turning
 - Taper Turning
 - Knurling
1. Fix the work piece rigidly in the chuck with the help of chuck key.
 2. Ensure that the work piece is held tightly in the chuck.
 3. The H.S.S tool bit is positioned in the tool post such that the centre of cutting tool coincides with the dead centre of chuck.
 4. For **facing operation** the cutting tool is kept at an angle to the axis of the given work piece and the cutting process is done by rotating the work piece relative to the tool.
 5. After facing operation is done the diameter of the work place is to be reduced according to the given dimensions by turning process, such that a step is formed on the work piece. Hence this complete the step turning operation.
 6. In **taper turning operation** change the tool post to the required position as per the taper angle obtained from the calculations.
 7. After fixing the tool position the relative motion is obtained by providing the feed with help of compound rest.
 8. For the **knurling operation** fix knurling tool and perform the knurling operation.
 9. The work piece is supported with mandrel at the tail stock.
 10. Hence step turning, taper turning and Knurling operations are performed on lathe.

Sketch:

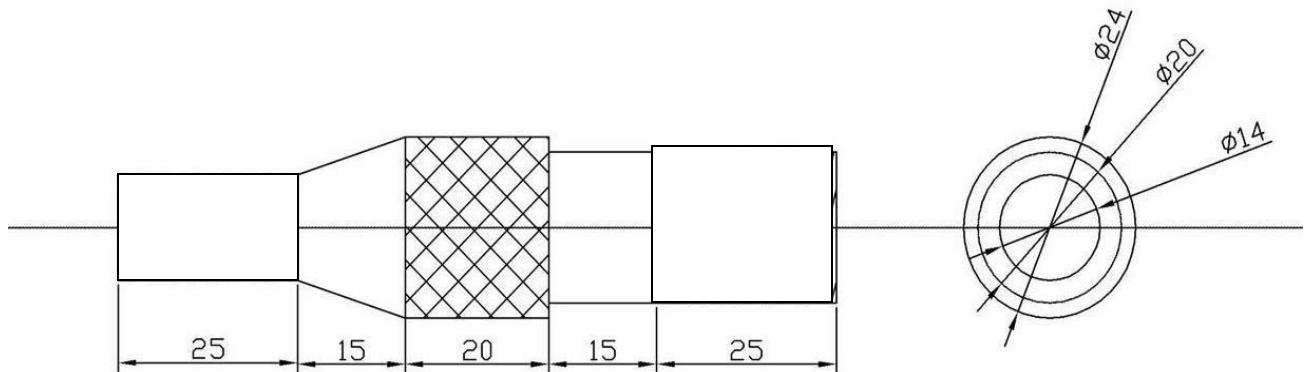

Precautions:

1. Make sure that the work piece is fixed tightly in the chuck.
2. Chuck key should be removed before starting the motor.
3. Person working on the machine should stay away from moving parts.
4. Appropriate feed, speed and depth of cut should be given.

Space For Calculations

RESULT & CONCLUSIONS:

Hence the step turning, taper turning & knurling operations are successfully performed on lathe.

VIVA QUESTIONS:

- What are the Various Operations performed on lathe?
- List out specifications of Lathe Machine
- Explain different methods to do taper turning.
- What is the Materials used in manufacturing of tools and various parts of lathe machine
- What is the need of Cutting fluids?
- What are principal parts of the lathe?
- Define the term ‘Conicity’?
- List any four types of lathe?
- What is an apron

EXPERIMENT - 10

THREAD CUTTING

AIM:

To perform single start and multi start threading cutting operation on lathe.

APPARATUS:

Machinery or Tools Required:

- Lathe
- Steel rule
- Outside callipers
- High speed steel tool bit
- Chuck key
- Tool post with key

Material Specification:

- Mild steel rod of 25mm diameter 100mm length.

THEORY:

Lathe removes undesired material from a rotating work piece in the form of chips with the help of a tool which is traversed across the work and can be fed deep in work. The tool material should be harder than the work piece and the later help securely and rigidly on the machine. The tool may be given linear motion in any direction. A lathe is used principally to produce cylindrical surfaces and plane surfaces, at right angles to the axis of rotation. It can also produce tapers and bellows etc.

A lathe basically consists of a bed to provide support, a head stock, a cross slide to traverse the tool, a tool post mounted on the cross slide. The spindle is driven by a motor through a gear box to obtain a range of speeds. The carriage moves over the bed guide ways parallel to the work piece and the cross slide provides the transverse motion. A feed shaft and lead screw are also provided to power the carriage and for cutting the threads respectively.

Specification of Lathe:

Length of bed: _____ mm

Width of bed: _____ mm

Height of centres: _____ mm

Admit between centres: _____ mm

Lead screw pitch: _____ mm

Power of the motor: _____ H.P.

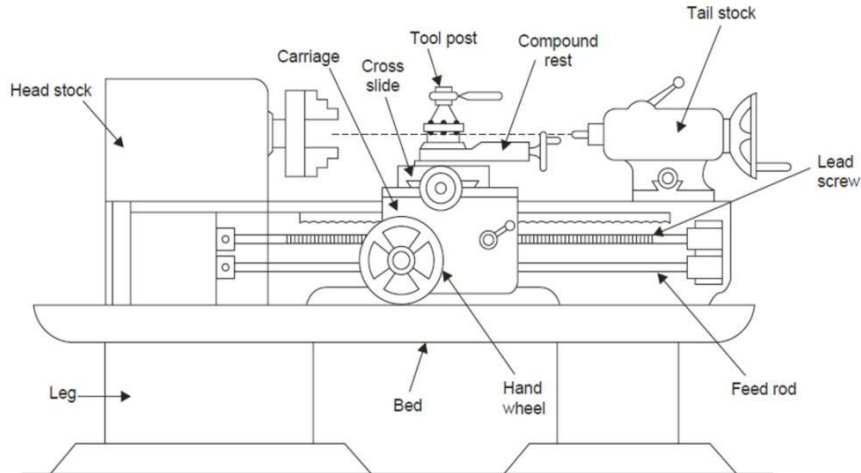

PROCEDURE:

1. Fix the work piece rigidly in the chuck with the help of chuck key.
2. Ensure that the work piece is held tightly in the chuck.
3. The H.S.S tool bit is positioned in the tool post such that the centre of cutting tool coincides with the dead centre of chuck.
4. In **thread cutting** we will engage carriage to the lead screw and the feed in thread cutting is provided by the half nut attachment.
5. The complete depth of the thread cannot be obtained in a single cut. Several cuts have to be taken, one after the other till required depth is obtained. At the end of the cut the tool is withdrawn as usual and the machine is stooped. Then the carriage is brought back to its starting position by reversing the direction of rotating of the lead screw.
6. Hence step turning, taper turning, Knurling and thread cutting operations are performed on lathe.

Sketch:

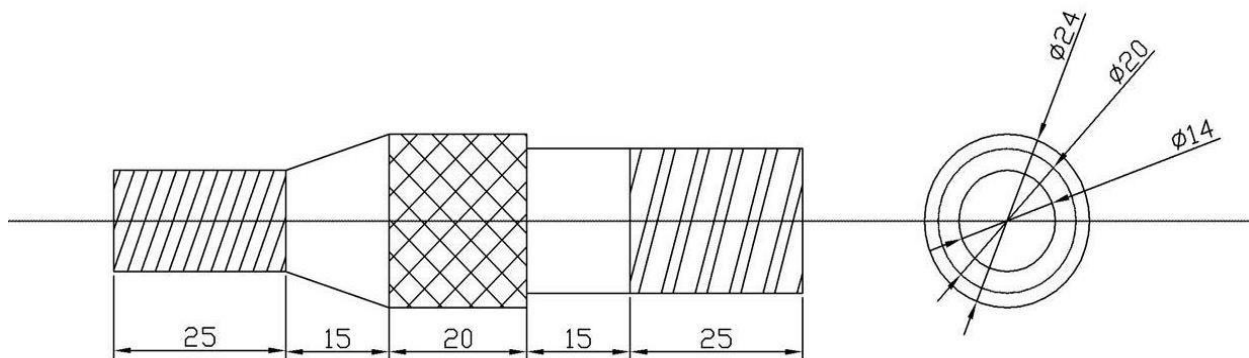

Precautions:

1. Make sure that the work piece is fixed tightly in the chuck.
2. Chuck key should be removed before starting the motor.
3. Person working on the machine should stay away from moving parts.
4. Appropriate feed, speed and depth of cut should be given.

Space For Calculations

RESULT & CONCLUSIONS:

Hence the single start and multi start thread cutting operations are successfully performed on lathe.

VIVA QUESTIONS:

- What is threading?
- What is steep taper turning?
- What is pitch and how it is measured?
- What is the difference between pitch and lead?
- What are the different forms of threads?
- What is the speed used for thread cutting and knurling?
- How threads of different pitches are obtained on lathe?
- What is chamfering? What is the standard angle and length of chamfering?
- What is the necessity of doing chamfering?

EXPERIMENT - 11 GEAR MILLING

AIM:

To mill the spur gear on the given circular blank of aluminium

APPARATUS:

Machinery & Tools Required:

- Milling machine
- Milling cutter
- simple indexing attachment.
- Simple Indexing • Compound Indexing • Differential Indexing

Material Specification:

- Circular blank of Al mm dia to make _____ number of teeth.

THEORY:

Milling is the cutting operation that removes metal by feeding the work against a rotating cutter having single or multiple cutting edges. Flat or curved surfaces of many shapes can be machined by milling with good finish and accuracy. A milling machine may also be used for drilling, making a circular profile and gear cutting by having suitable attachments.

Spur may be cut or ground on a milling machine utilizing a numbered gear cutter, and any indexing head or rotary table. The number of the gear cutter is determined by the tooth count of the gear to be cut.

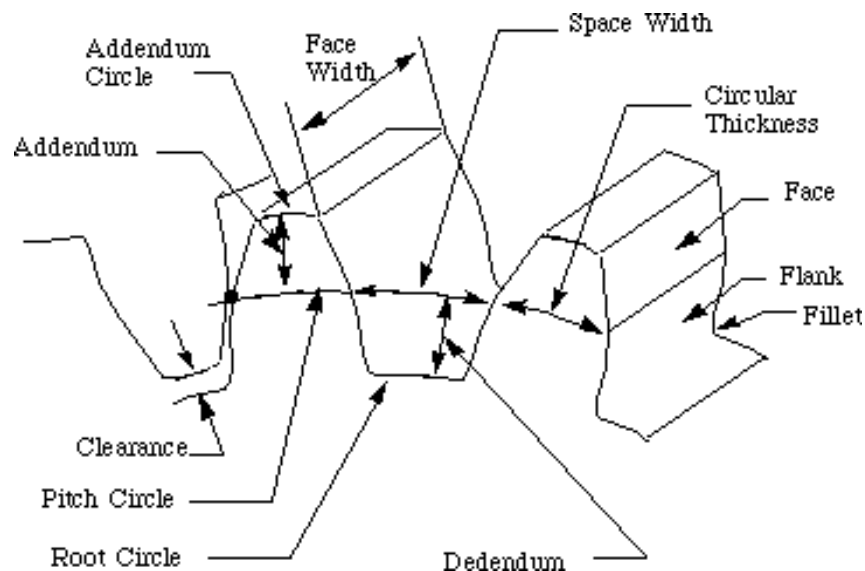

Simple Indexing: Indexing is an operation of dividing a periphery of a cylindrical workpiece into equal number of divisions by the help of index crank and index plate. A manual

indexing head includes a hand crank. Rotating the hand crank in turn rotates the spindle and therefore the workpiece. The hand crank uses a worm gear drive to provide precise control of the rotation of the work. The work may be rotated and then locked into place before the cutter is applied, or it may be rotated during cutting depending on the type of machining being done.

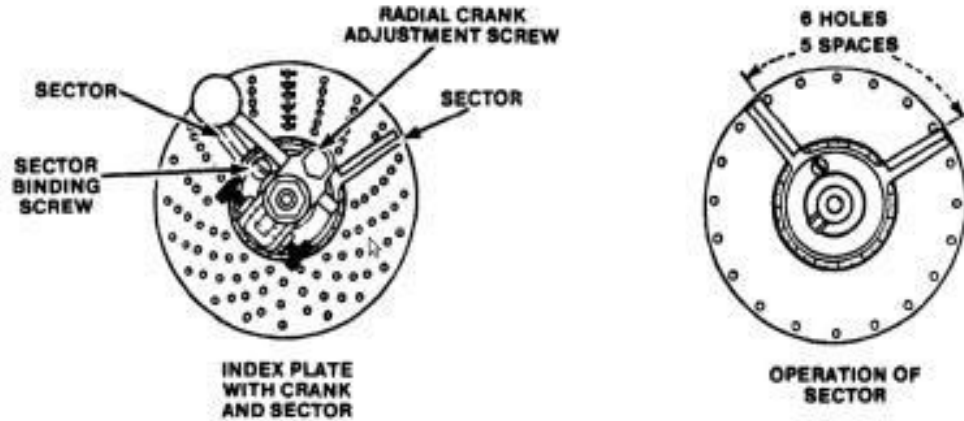

It is achieved by using index plates while the main spindle is rotated by turning the index crank. The choice and use of suitable index plates generally extends the range of indexing and the majority of divisions can be obtained in this way.

The rule for simple indexing is:

- Divide 40 by the number of divisions required.
- The quotient obtained gives the number of turns or parts of a turn of the index crank required for the given number of divisions.
- The circle of holes chosen must be a multiple of the denominator of the fraction obtained.

Turns of index = $\frac{40}{N}$ crank Where, N = Number of divisions or cuts required.

Let No of teeth required = 24

Then turns of index = $\frac{40}{24} = \frac{5}{3} = 1 \frac{2}{3}$

Multiplying and dividing with 5, then we have

Turns of index = $1 \frac{10}{15}$

It means after completion of first teeth rotate the indexing crank through 1 revolution + 10 Holes to be moved in the 15 holes plate to start second gear teeth.

- Plate 1: 15, 16, 17, 18, 19 holes
- Plate 2: 21, 23, 27, 29, 31, 33 holes
- Plate 3: 37, 39, 41, 43, 47, 49 holes

PROCEDURE:

1. Fix the circle blank rigidly in the work holding device.
2. Determine the gear tooth proportions.
3. Set up the speed and feed, apply the speed less than the plain milling operations and the feed is normal
4. Fix the dividing head and the tail stock on the table exactly perpendicular to the machine spindle

5. Check up the alignment of the cutter (note that the centre line of the cutter coincides with the centre point of tail stock)
6. Fix the circular gear between the two centres by a mandrel to is connected with the dividing head spindle by carrier and catch plate
7. Fix the proper index plate on the dividing head to adjust the position of the crank pin to sector arm
8. Raise the table till the cutter just touches the periphery of the circular gear blank
9. Select vertical feed at zero and raise the table to give the required depth of cut by turning the dial through, calculate the number of divisers
10. Start the machine to apply the feed to cut the first tooth space of the gear
11. Bring the table track to the starting position after the end of the cut
12. Index the blank for the next tooth space
13. Repeat the same till all the gear tooth are cut in the blank

Precautions:

1. Always keep the machine perfectly clean thoroughly cited
2. Always use correct speed and feed

Space For Calculations

RESULT & CONCLUSIONS:

Given circular gear blank is to be killed to spur gear of required number of tooth on its periphery according to the dimensions.

VIVA QUESTIONS:

- What is milling?
- How is the size of the milling machine specified?
- What are the different types of milling machines?
- Which type of measuring tool is used for marking of dimensions?
- What are the three types dividing heads?
- What is cam milling?
- Mention the various movements of the universal milling machine table?
- State any two comparisons between plain & universal milling machine?
- Explain Indexing and types of indexing methods.
- Explain gear terminology.
- List the various types of milling attachment?
- Write any ten nomenclature of plain milling cutter?
- List out the various milling operations?

EXPERIMENT - 12

DRILLING AND TAPPING

AIM:

To perform drilling and tapping operations.

APPARATUS:

Machinery or Tools Required:

- Drilling machine
- Drill bit
- Tap
- Tap holder
- Drill chuck and key
- Coolant oil.

Material Specification:

Mild steel _____, Drill _____mm, Tap _____

THEORY:

Drilling machine is one of the simplest, moderate and accurate machine tool used in production shop and tool room. It consists of a spindle which imparts rotary motion to the drilling tool, a mechanism for feeding the tool into the work, a table on which the work rests. It is considered as a single purpose machine tool since its chief function is to make holes.

Drilling is a cutting process that uses a drill bit to cut a hole of circular cross-section in solid materials.

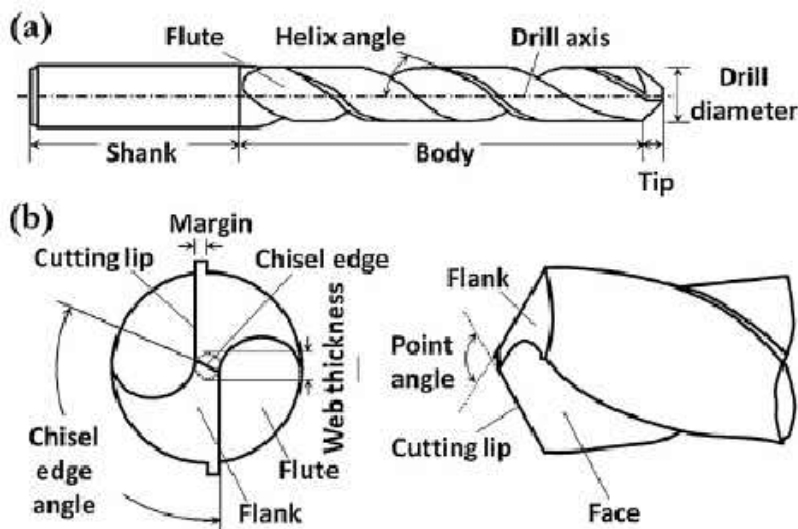

The drill bit is usually a rotary cutting tool, often multi-point. For fluted drill bits, any chips are removed via the flutes. Chips may form long spirals or small flakes, depending on the material, and process parameters

Taps: A tap cuts or forms a thread on the inside surface of a hole, creating a female surface which functions like a nut.



PROCEDURE:

1. Fix the work piece in bench vice rigidly.
2. Place the work piece exactly under the drill bit at the required part to make the drill.
3. The tool is revolved at a required speed and it is brought into contact with the work piece by moving feed handle up and down. Hence by these continuous operations the hole is made on the work piece.
4. For tapping the size of the hole to be made through is drilling has to be smaller than the size of the tap.
5. The work piece is held rigidly in the vice and tapping is done in the specimen by rotating the tap gently in anticlockwise and clockwise directions.
6. Hence the drilling and tapping operations are performed.

Sketch:

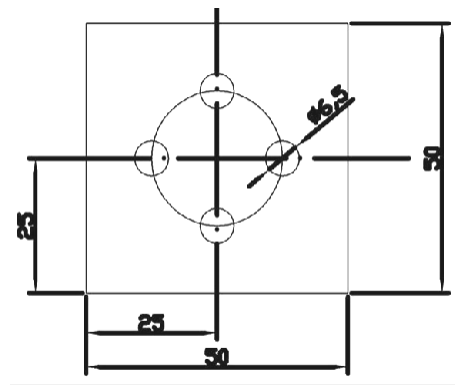

Precautions:

1. Always use a correct size drill.
2. Select a proper tool material - high carbon steel, H.S.S or carbide tipped, that will suit the hardness of the work material.
3. Always maintain the cutting speed within the permissible range.
4. Ensure that the work piece is properly supported before starting the operations.
5. Ensure that the chips continue to flow out of the drilled hole in order to avoid drill clogging, excess heat generation and possible breakage of drill.
6. Use correct drill geometry, specially the tip clearance angle.
7. Do not wear loose clothing.
8. Always use protective eye shield.

Space For Calculations

RESULT & CONCLUSIONS:

Hence the drilling and tapping operations are performed successfully according to the dimensions.

VIVA QUESTIONS:

- List out different types of drilling machines
- Explain drilling, Reaming and tapping processes.
- Mention the specification of drilling machine
- Explain drill bit tool nomenclature
- What are the different ways to mount the drilling tool?
- List any four machining operations that can be performed on a drilling machine?

EXPERIMENT - 13

SHAPING

AIM:

To machine the surface of a work piece with shaper.

APPARATUS:

Machinery or Tools Required:

- Shaper
- Steel rule
- Try square
- H.S.S tool bit.

Material Specification:

Mild steel 20mm square

THEORY:

Working Principle

The working principle of a shaper is illustrated in fig1.

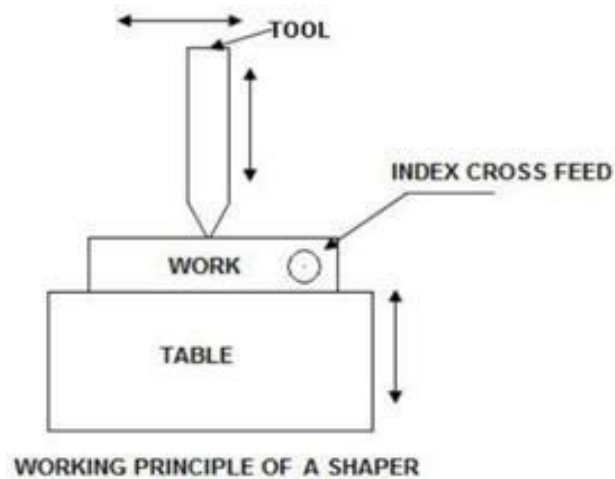

In case of shaper; the job is rigidly held in a suitable device like a vice or clamped directly on the machine table. The tool is held in the tool post mounted on the ram of the machine. This ram reciprocates to and fro and in doing so makes the tool to cut the material in the forward stroke. No cutting of material takes place during the return stroke of the ram. Hence it is termed as idle stroke. However in case of a draw cut shaper the cutting takes place in the return stroke and the forward stroke is an idle stroke. The job is given an index feed in a direction normal to the line of action of the cutting tool.

Principal Parts of a Shaper

Principal parts of a shaper as illustrated in fig are the following.

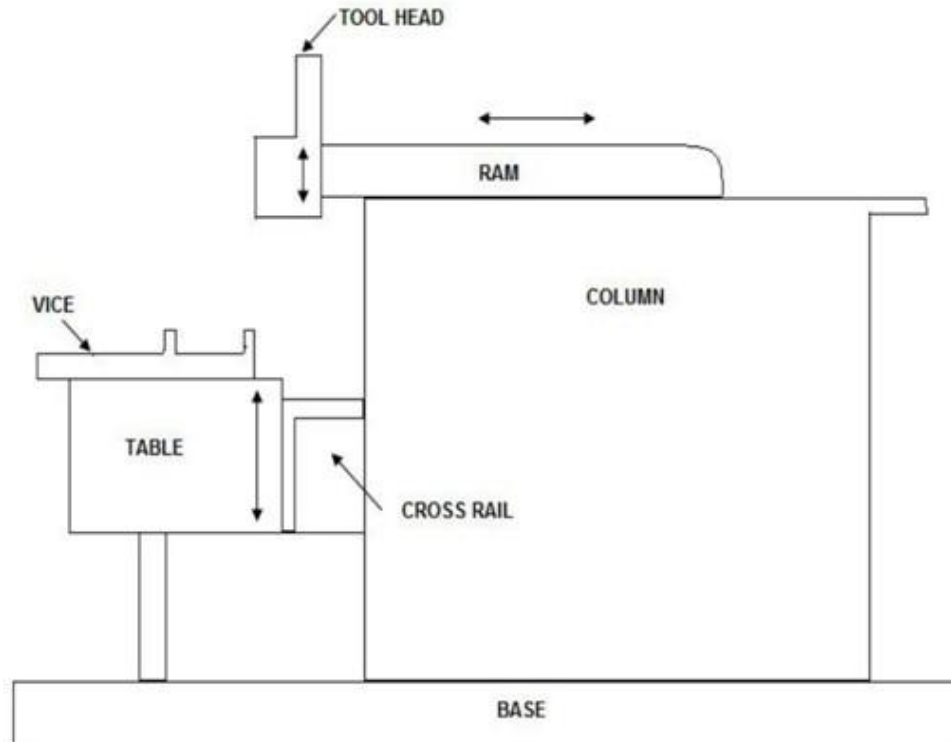

MAIN PARTS OF A SHAPER

- Base: It is a heavy and robust cast iron body which acts as a support for all the other parts of the machine which are mounted over it.
- Column: It is a box type cast-iron body mounted on the base acts as housing for the operating mechanism of the machine and the electrical. It also acts as a support for other parts of the machine such as cross rail and ram etc.
- Cross rail: It is a heavy cast iron construction attached to the column at its front on the vertical guide ways. It carries two mechanisms: one for elevating the table and the other for cross traversing of the table.
- Table: It is made of cast iron and has a box type construction. It holds and supports the work during the operation and slides along the cross rail to provide feed to the work.
- Ram: It is also an iron casting, semi circular in shape and provides with a ribbed construction inside for rigidity and strength. It carries the tool head and travels in dovetail guide ways to provide a straight line motion to the tool.
- Tool head: It is a device in which is held the tool. It can slide up and down and can be swung to a desired angle to set the tool at a desired position for the operation.
- Vice: It is a job holding device and is mounted on the table. It holds and supports the work during the operation.

PROCEDURE:

1. Fix the work piece rigidly in the work holding device.
2. The stroke length of the shaper is adjusted according to the job length.
3. After setting the work piece and tool on the required positions the movement to the shaper is given.

4. After series of these strokes the required dimensions of the work piece is obtained.
5. Hence the machining of the work piece is done by shaper.

Precautions:

1. Always keep the machine perfectly clean and thoroughly oiled.
2. Never hammer a piece, having rough surface, against or parallel.
3. Ensure before use, that the parallels are free from burrs.
4. Ensure that the clapper block swings freely out during the return stroke.
5. Adjust the proper length of stroke before starting the operation.
6. Always use correct speed and feed.

Space For Calculations

RESULT & CONCLUSIONS:

Hence the machining of a work piece is successfully done by shaper.

VIVA QUESTIONS:

- What is the mechanism used in shaping machine
- What is shaper?
- List any four important parts of a Shaper?
- How the feed & depth of cut given to the shaper?
- Mention any four-shaper specification?
- How does the planer differ from the shaper?

EXPERIMENT - 14

LATHE TOOL DYNAMOMETER

AIM:

To measure the cutting forces with the help of Lathe Tool Dynamometer and shear stress

APPARATUS:

Machinery & Tools Required:

- Lathe machine
- Lathe Tool Dynamometer

Tool Specification:

- HSS tool with tool holder, $\Phi 25\text{mm}$ MS bar

THEORY:

In machining or metal cutting operation the device used for determination of cutting forces is known as a Tool Dynamometer or Force Dynamometer.

Majority of dynamometers used for measuring the tool forces use the deflections or strains caused in the components, supporting the tool in metal cutting, as the basis for determining these forces. In order that a dynamometer gives satisfactory results it should possess the following important characteristics:

- It should be sufficiently rigid to prevent vibrations.
- At the same time it should be sensitive enough to record deflections and strains appreciably.
- Its design should be such that it can be assembled and disassembled easily.
- A simpler design is always preferable because it can be used easily.
- It should possess substantial stability against variations in time, temperature, humidity etc.
- It should be perfectly reliable.
- The metal cutting process should not be disturbed by it, i.e. no obstruction should be provided by it in the path of chip flow or tool travel.

Types of Dynamometers:

Irrespective of their design and the technique used for strain measurement, most of the force dynamometers used today carry a measuring system which is pre-calibrated for its stiffness. The cutting forces are measured by these dynamometers by measuring the strain or deflection caused in this system due to the force under measurement. The different types of commonly used dynamometers can be broadly classified as:

- Mechanical dynamometers
- Strain Gauge type dynamometers

- Pneumatic and Hydraulic dynamometers
- Electrical Dynamometers
- Piezoelectric dynamometers

PROCEDURE:

Lathe tool dynamometer is used to measure cutting forces acting at the machining zone during turning with a single point cutting tool. All the three directional forces are measured simultaneously.

Forces on a single point tool in turning:

In case of oblique cutting in which three component forces act simultaneously on the tool point as shown. The components are:

1. F_t = The feed force or thrust force acting in horizontal plane parallel to the axis of the work.
2. F_r = The radial force, also acting in the horizontal plane but along a radius of Work piece i.e. along the axis of the tool.
3. F_c = The cutting force, acting in vertical plane and is tangential to the work surface. Also called the tangential force.

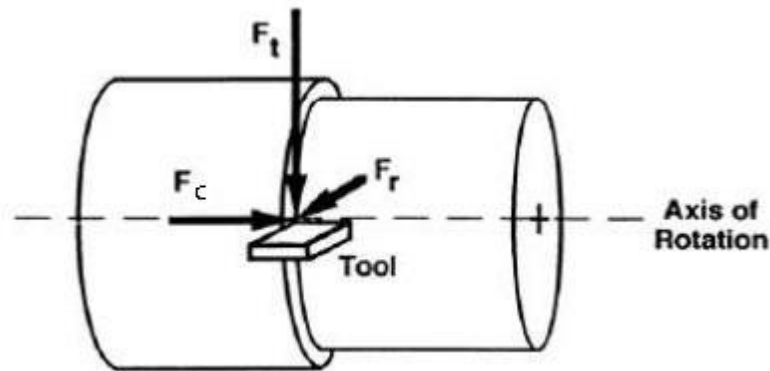

7. The work piece is fixed in a 3-jaw chuck with sufficient overhang.
8. Fix the dynamometer cutting tool in the tool post in such a way that the tip of the tool coincides with the lathe axis.
9. Select proper cutting speed, feed and depth of cut.
10. Perform turning operation on the work.
11. Directly measure the three components of forces acting on the tool using lathe tool dynamometer.
12. Repeat the procedure for varying the above three parameters (N, F & DC).
13. The resultant force can be calculated by $R = \sqrt{F_c + F_t + F_r}$
14. Observe the effect of cutting speed, feed and depth of cut on force.

Table:

S. NO	Speed (N)	Feed (f)	Depth of cut (DC)	Forces			Resultant
				F_x	F_y	F_z	
1.							
2.							
3.							

Precautions:

1. The tool should be rigidly mounted on the lathe tool post.
2. Make sure that there should not be any vibrations in the tool.
3. Readings should be noted carefully.
4. Select the cutting speed, feed and depth of cut properly.
5. Always keep the machine perfectly clean thoroughly cited
6. Always use correct speed and feed

Space For Calculations

RESULT & CONCLUSIONS:

1. $F_t =$
2. $F_r =$
3. $F_c =$

VIVA QUESTIONS:

- Explain Merchant Cycle
- How is the cutting speed calculated?
- How is the Feed calculated?
- Compare an orthogonal system with an oblique system in metal cutting. .
- Explain the terms Frictional force, shear force, normal force.

EXPERIMENT - 15

SHEAR ANGLE

AIM:

To determine the shear angle by measuring chip thickness and length of chip

APPARATUS:

Machinery & Tools Required:

- Lathe machine

Tool Specification:

- Tool signature 15° -6°-20°-15°-10°-8°-4mm (ASA)

THEORY:

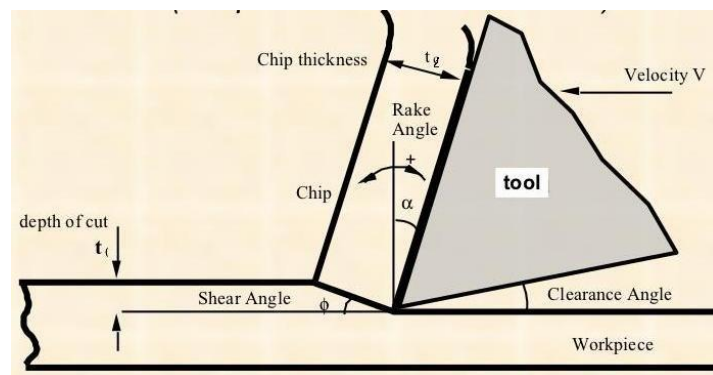

$t_1 = \text{depth of cut} = \text{uncut chip thickness}$

$t_2 = \text{chip thickness}$

$\alpha = \text{Rake angle} = \text{_____}$

$\Phi = \text{Shear angle}$

$l_1 = \text{length of uncut chip}$

$l_2 = \text{length of chip}$

$w = \text{width (almost equal in chip and uncut chip)}$

As per Volume consistency condition, Volume of uncut chip = volume of chip

i.e's $t_1 l_1 w = t_2 l_2 w$

$$\frac{t_1 l_1}{1} = \frac{t_2 l_2}{2} \implies \frac{t_1}{t_2} = \frac{l_2}{l_1} = r = \text{chip thickness ratio}$$

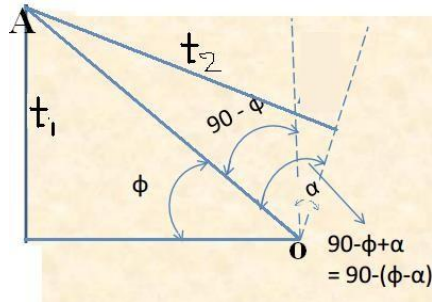

$$OA = \frac{t_1}{\sin \phi} \quad \text{and}$$

$$OA = \frac{t_2}{\sin(90 - (\phi - \alpha))}$$

$$\text{From both the equations we have} \quad OA = \frac{t_1}{\sin \phi} = \frac{t_2}{\sin(90 - (\phi - \alpha))}$$

$$\frac{t_1}{\sin \phi} = \frac{t_2}{\cos(\phi - \alpha)}$$

$$\frac{t_2}{t_1} = \frac{\cos(\phi - \alpha)}{\sin \phi} = \frac{\cos \phi \cos \alpha + \sin \phi \sin \alpha}{\sin \phi}$$

$$\frac{t_2}{t_1} = \frac{\cos \phi \cos \alpha}{\sin \phi} + \frac{\sin \phi \sin \alpha}{\sin \phi}$$

$$\frac{t_2}{t_1} = \cot \phi \cos \alpha + \sin \alpha$$

$$\frac{t_2}{t_1} - \sin \alpha = \cot \phi \cos \alpha$$

$$\frac{\frac{t_2}{t_1} - \sin \alpha}{\cos \alpha} = \cot \phi$$

$$\tan \phi = \frac{\cos \alpha}{\frac{t_2}{t_1} - \sin \alpha}$$

$$\phi = \tan^{-1} \left(\frac{\cos \alpha}{\frac{t_2}{t_1} - \sin \alpha} \right)$$

Or

$$\phi = \tan^{-1} \left(\frac{\cos \alpha}{\frac{t_1}{t_2} - \sin \alpha} \right)$$

From here shear angle can be determined

PROCEDURE:

1. A tool of known nomenclature is taken.
2. Depth of cut must be noted accurately which is uncut chip thickness
3. After cutting chip thickness is measured by means of a micrometer.
4. By substituting the values of uncut chip thickness and chip thickness and rake angle of tool in the shear angle equation we can determine shear angle.

Table:

S. NO	Uncut chip thickness (t_1)	Chip Thickness (t_2)	$\frac{t_2}{t_1}$	$\phi = \tan^{-1} \left(\frac{\cos \alpha}{\frac{t_2}{t_1} - \sin \alpha} \right)$
1.				
2.				
3.				

Precautions:

1. Always keep the machine perfectly clean thoroughly cited
2. Always use correct speed and feed

Space For Calculations

RESULT & CONCLUSIONS:

Average Shear angle obtained is equal to _____

VIVA QUESTIONS:

- List out different types of chips.
- What is the chip thickness ratio?
- Mention the relation between shear angle, rake angle and chip thickness.
- What is the built up edge formation?
- Explain temperature distribution in the chip and tool.

EXPERIMENT - 16

GEOMETRICAL TESTS ON LATHE MACHINE

AIM:

To perform various alignment tests on Lathe.

APPARATUS:

- i) Dial gauges
- ii) Test mandrels
- iii) Straight edges and squares
- iv) Spirit levels etc
- v) Angle brackets

THEORY:

Machine Tool tests:

In most cases the production or machining of a given geometric surface is achieved through combination of work-tool movements. In other words, the machined surface is generated, and the accuracy of the surface depends on the accuracy of the mating elements present in the machine tool.

The various tests applied to any machine tool could be grouped as below.

- a) Tests for the level of installation of machine in horizontal and vertical planes.
- a) Tests for flatness of machine bed and for straightness and parallelism of bed ways or bearing surfaces.
- b) Tests for perpendicularity of guide ways to other guideways or bearing surfaces.
- c) Tests for the true running of the main spindle and its axial movements.
- d) Tests for parallelism of spindle axis to guide ways or bearing surfaces.
- e) Tests for the line of movement of various members, i.e. saddle and table cross-slides etc. along their ways.

PROCEDURE:

Alignment test on lathe:

Leveling of the machine: The level of the machine bed in longitudinal and transverse directions is tested by a sensitive spirit level. The saddle is kept approximately in the centre of the bed support feet. The spirit level is then placed at a-a (Fig 7.1), to ensure the level in the longitudinal direction. It is then traversed along the length of bed and readings at various places noted down.

For tests in transverse direction the level is placed on a bridge piece to span the front and rear guide ways and their reading is noted. It is preferable to take two readings in longitudinal and transverse directions simultaneously so that the effect of adjustments in one direction may also be observed on the other. The readings in transverse direction can reveal any twist in the bed. It may be noted that the two guide ways may be perfectly leveled in longitudinal direction, but might not be parallel to each other. This is revealed by the test in transverse direction.

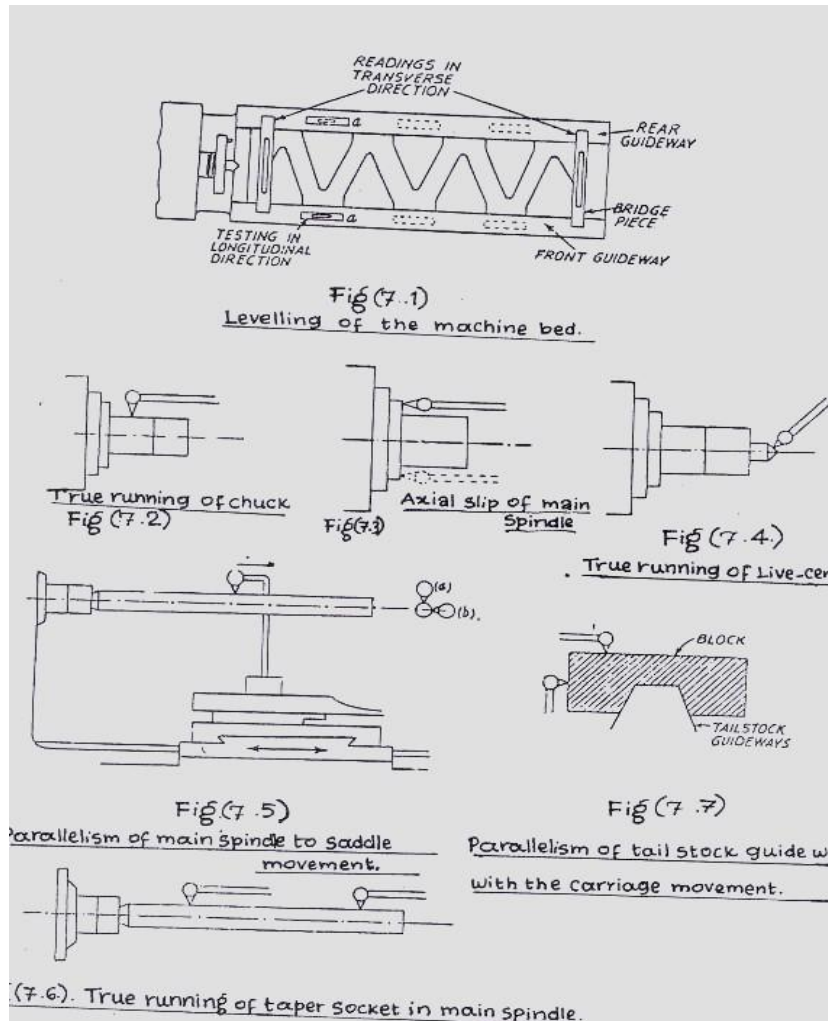

True Running of Locating Cylinder of Main Spindle:

Locating cylinder is provided to locate the chuck or face plate and the true running of which depends on true running of the locating cylinder.

The dial indicator is fixed to the carriage (or any other fixed member) and the feeler of the indicator touches the locating surface as shown in fig (7.2). The surface is then rotated on its axis and indicator should not show any movement of needle. If there is any change in the indicator reading, it must be recorded and be verified with the limiting values.

Axial Slip of Main Spindle and True Running of Shoulder Face of Spindle

Nose:

Axial slip is the movement of the spindle in axial direction and is due to the manufacturing error. To test this, the feeler of the dial gauge rests on the face of the locating spindle shoulder and the dial gauge holder is clamped to the bed as shown in fig (7.3). The locating cylinder is then rotated and the change in reading noted down. The readings are taken at two diametrically opposite points. The total error indicated by the movement of the pointer includes three main sources of errors.

- i) Axial slip due to error in bearings supporting the locating shoulder, i.e. the bearings are not perpendicular to the axis of rotation and due to it a point on the shoulder will move axially in & out at diametrically opposite points,
- ii) Face of the locating shoulder not in a plane perpendicular to the axis of rotation

- iii) Irregularities of front face. Due to axial slip, in screw cutting, the pitch will not be uniform due to periodic movement of the spindle.

True running of Live centre:

Work piece is rotated along with the Live centre. If it is not true with the axis of movement of the spindle, eccentricity will be caused while turning a work, as the job axis would not coincide with the axis of rotation of the main spindle.

For testing this error, the feeler of the dial indicator is pressed perpendicular to the taper surface of the centre as shown in fig (7.4), and the spindle is rotated. The deviation indicated by the dial gauge gives the trueness of the centre.

Parallelism of the main spindle to Saddle movement:

If the axis of the spindle is not parallel to bed in horizontal direction, a tapered surface is produced. Any deviation from parallelism of spindle axis from bed in vertical axis will produce a hyperboloid surface. For this test, a mandrel is fitted in the taper socket of the spindle. Mandrel has a concentric taper shank which is a close fit to the spindle nose taper. The feeler of the dial-indicator is pressed on the mandrel and the carriage is moved. The indication in the horizontal plane is given by dial (b) and in vertical plane by dial (a) as shown in fig (7.5).

Running of taper socket in main spindle:

If the tapered hole of the socket is not concentric with the main spindle axis, eccentric and tapered jobs will be produced. To test it, a mandrel is fitted into the tapered hole and readings at two extremes of the mandrel are taken by means of a dial indicator as shown in fig (7.6).

Parallelism of tail stock guide ways with the movement of carriage:

Sometimes the job is held between headstock and tailstock for turning. In that case, they axis must coincide with the tailstock centre. If the tail stock guide ways are not parallel with the carriage movement there will be some offset of the tailstock centre results in taper turning To check the parallelism of tail stock guide ways in horizontal and vertical planes, a block placed on the guide was as shown in fig (7.7) and the feeler of the indicator is touched on the horizontal and vertical surfaces of the block. The dial indicator is held in the carriage and carriage is moved. Any error is indicated by the pointer of dial indicator.

Movement of upper slide parallel with main spindle in vertical plane:

The dial indicator is fixed in the tool post. A mandrel is fitted in the spindle. The feeler of the dial gauge is pressed against the mandrel in vertical plane and the upper slide is moving longitudinally. This error is not tested in horizontal plane because there is swiveled arrangement for taper running.

Parallelism of tail stock sleeve to saddle movement:

If the tailstock sleeve is not parallel to the saddle movement, the height of dead centre would vary as varying lengths of sleeves are taken out. For the jobs held between two centers, it is necessary that the central axis of the dead centre be coaxial with the job axis in both the plane If it is not so, the job may be tilted up or down or sideways due to the support of the de; centre. The test is carried out by fixing the dial indicator on the tool post and pressing tl plunger against the sleeves first vertically and then in horizontal plane as shown in fig (7.8) The carriage is moved along the full length of the sleeve and the deviations as indicated by di indicator are noted down.

Parallelism of tail stock sleeve taper socket to saddle movement:

A mandrel is put in the sleeve socket. The dial gauge is on the tool post and plunger is press* against the mandrel and saddle is moved from fixed one side to the other. This test is came out in both the horizontal and vertical planes as shown in fig (7.10).

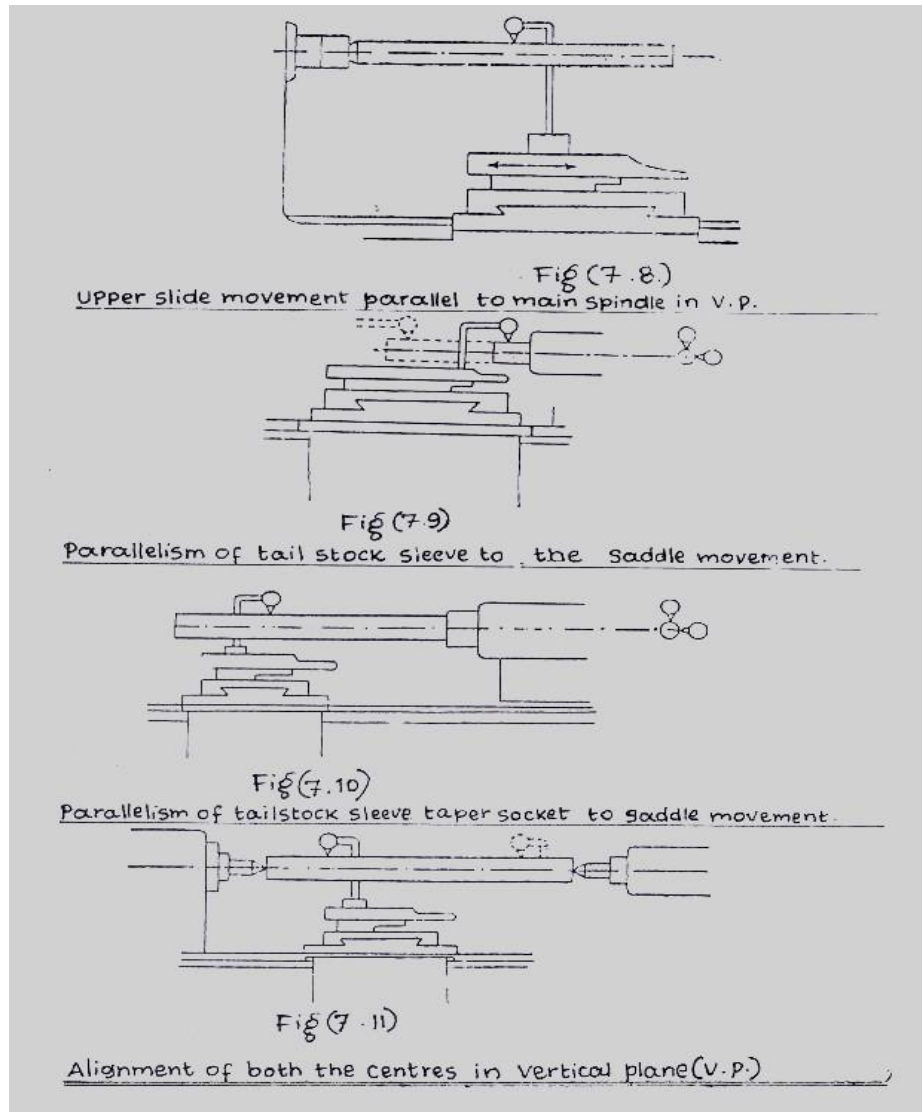

Alignment of both the centers in vertical plane:

Besides testing the parallelism of the axes individually (main spindle axis and tail stock axis it is necessary to check the relative position of the axes also. Both the axes may be parallel carriage movement but they may not be coinciding. So when a job is fitted between the centre axis of the job will not be parallel to the carriage movement. This test is to be carried out in vertical plane only. A mandrel is fitted between the two centers and dial gauge on the carriage The feeler of the dial gauge is pressed against the mandrel in vertical plane as shown in fi (7.11) and the carriage is moved and error noted down.

Precautions:

1. The mandrel must be so proportioned that its overhang does not produce appreciable sag, else the sag must be calculated and accounted for.
2. The indicator setup must be rigid, otherwise variations in readings as recorded by point may be solely due to deflection of the indicator.

Space For Calculations

RESULT & CONCLUSIONS:

VIVA QUESTIONS:

- What is the necessity of conducting various alignment tests on lathe?
- What are the various alignment tests to be conducted on the lathe?
- What is straightness?
- What is flatness?
- What is squareness?
- What is parallelism?
- What do you mean by axial slip of main spindle?
- It is necessary to conduct alignment tests on other machine tools? If so why? Not, why not?

EXPERIMENT - 17

DRILLING & BORING

AIM:

To perform boring operation for MS rod on lathe machine

APPARATUS:

Machinery or Tools Required:

- Lathe
- Drill bit of 25mm dia
- Chuck key
- Boring tool.

Material Specification:

- Mild steel rod of 50mm diameter & 30mm length.

THEORY:

Drilling is a cutting process that uses a drill bit to cut a hole of circular cross-section in solid materials. The drill bit is usually a rotary cutting tool, often multi-point. For fluted drill bits, any chips are removed via the flutes. Chips may form long spirals or small flakes, depending on the material, and process parameters

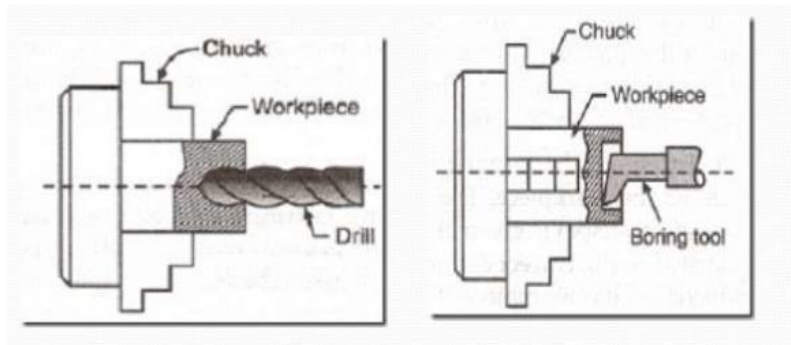

Boring is the process of enlarging a hole that has already been drilled (or cast) by means of a single-point cutting tool. Boring is used to achieve greater accuracy of the diameter of a hole, and can be used to cut a tapered hole.

Specification of Lathe:

- Length of bed: _____mm
- Width of bed: _____mm
- Height of centres: _____mm
- Admit between centres: _____mm
- Lead screw pitch: _____mm
- Power of the motor: _____H.P

PROCEDURE:

Sequence of Operations:

- Centering
 - Drilling
 - Boring
1. Fix the work piece rigidly in the chuck with the help of chuck key.
 2. Ensure that the work piece is held tightly in the chuck
 3. Drilling tool bit positioned such that centre of tool coincides the dead centre of tail stock
 4. Slowly drilling bit driven in to the MS specimen to make a through hole of 25mm diameter.
 5. Remove the drill bit from tail stock. Fix the boring tool on the tool post and perform the boring operation up to 40mm inner diameter
 6. Remove the boring tool from tool post, the MS specimen from the chuck
 7. Hence the drilling and boring operations are performed on lathe machine

Sketch

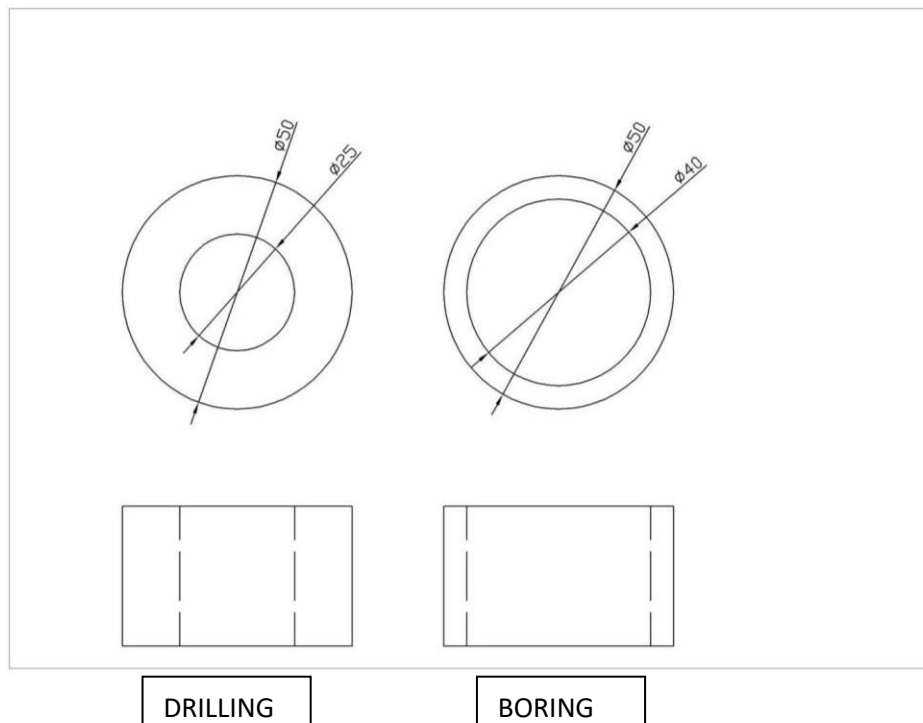

Precautions:

1. Make sure that the work piece is fixed tightly in the chuck.
2. Chuck key should be removed before starting the motor.
3. Person working on the machine should stay away from moving parts.
4. Appropriate feed, speed and depth of cut should be given.

Space For Calculations

RESULT & CONCLUSIONS:

Hence the boring operation successfully performed on lath

VIVA QUESTIONS:

- Compare Drilling and boring operations
- How the boring process is done on lathe.
- Mention the components of Carriage
- Mention the major Components of Lathe Machine.
- List out tools and work holding devices?

EXPERIMENT - 18

TOOL ANGLES

AIM:

Grinding of various tool angles according to American Standard Association of tool signature $15^\circ - 6^\circ - 20^\circ - 15^\circ - 10^\circ - 8^\circ - 4\text{mm}$.

APPARATUS:

Machinery Or Tools Required:

Bench grinding machine, tool & cutter machine

Material Specification:

H.S.S – $(3/8'') \times (3/8@) \times 10\text{mm}$

THEORY:

Single point cutting tool: As its name indicates, a tool that has a single point for cutting purpose is called single point cutting tool. It is generally used in the lathe machine, shaper machine etc. It is used to remove the materials from the workpiece.

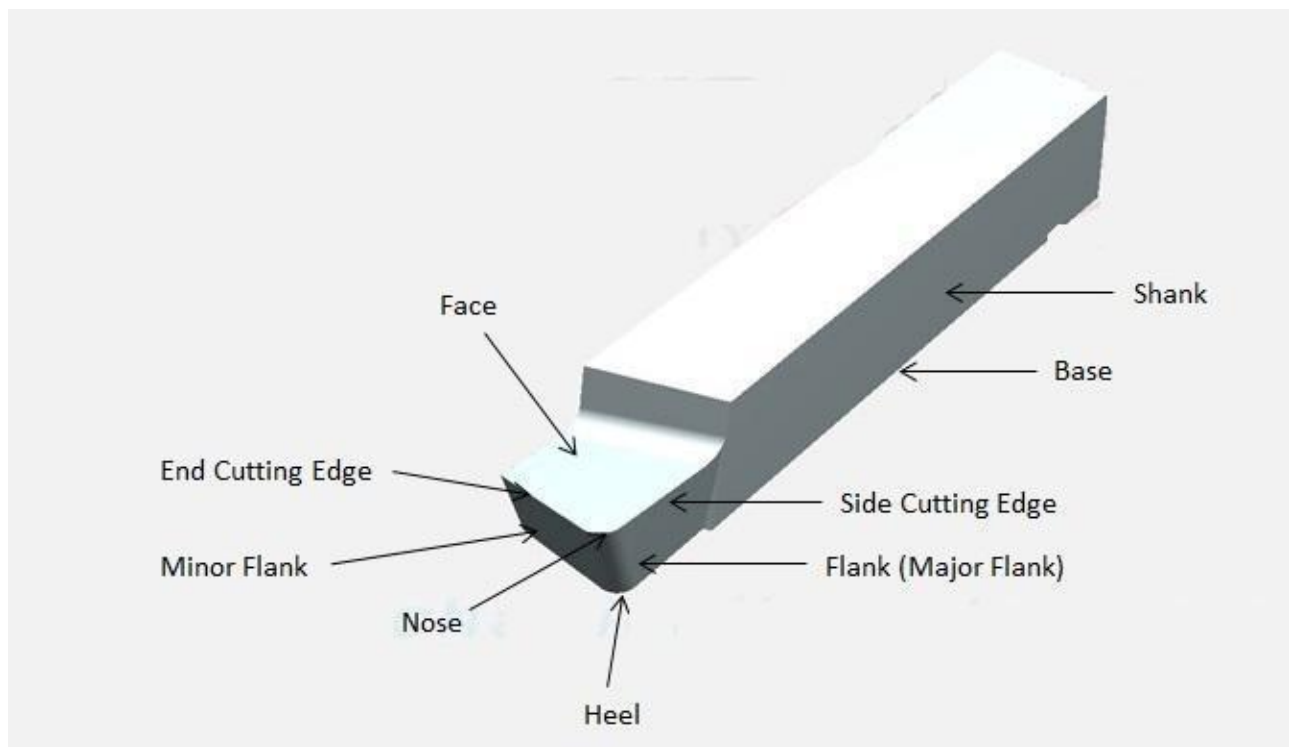

- 1. Shank:** It is that part of single point cutting tool which goes into the tool holder. Or in simple language shank is used to hold the tool.
- 2. Flank:** It is the surface below and adjacent of the cutting edges. There are two flank surfaces, first one is major flank and second one is minor flank. The major flank lies below and adjacent to the side cutting edge and the minor flank surface lies below and adjacent to the end cutting edge.

3. **Base:** The portion of the shank that lies opposite to the top face of the shank is called base.
4. **Face:** It is the top portion of the tool along which chips slides. It is designed in such a way that the chips slides on it in upward direction.
5. **Cutting edge:** The edge on the tool which removes materials from the work piece is called cutting edges. It lies on the face of the tool. The single point cutting tool has two edges and these are
 - (i) **Side cutting edge:** The top edge of the major flank is called side cutting edge.
 - (ii) **End cutting edge:** The top edge of the minor flank is called end cutting edge.
6. **Nose or cutting point:** The intersection point of major cutting edge and minor cutting edge is called nose.
7. **Nose radius:** It is the radius of the nose. Nose radius increases the life of the tool and provides better surface finish.
8. **Heel:** It is a curved portion and intersection of the base and flank of the tool.

Angles of Single Point Cutting Tool:

The various angles of the single point cutting tool have great importance. Each angle has its own function and speciality.

1. **End Cutting Edge Angle:** The angle formed in between the end cutting edge and a line perpendicular to the shank is called end cutting edge angle.
2. **Side Cutting Edge Angle:** The angle formed in between the side cutting edge and a line parallel to the shank.
3. **Back Rake Angle:** The angle formed between the tool face and line parallel to the base is called back rake angle.
4. **Lip Angle/ Wedge Angle:** It is defined as the angle between face and minor flank of the single point cutting tool.
5. **End Relief Angle:** The angle formed between the minor flank and a line normal to the base of the tool is called end relief angle. It is also known as front clearance angle. It avoid the rubbing of the workpiece against tool.
6. **Side Rake Angle:** the angle formed between the tool face and a line perpendicular to the shank is called side rake angle.
7. **Side Relief Angle:** the angle formed between the major flank surface and plane normal to the base of the tool is called side relief angle. This angle avoids the rubbing between workpiece and flank when the tool is fed longitudinally.

Nomenclature: There are three coordinate systems which are most popular in tool nomenclature. And these are

1. Machine Reference System or American Standards Association (MRS or ASA)
2. Orthogonal Tool Reference System (ORS) or Orthogonal Rake System
3. Normal Reference System (NRS)

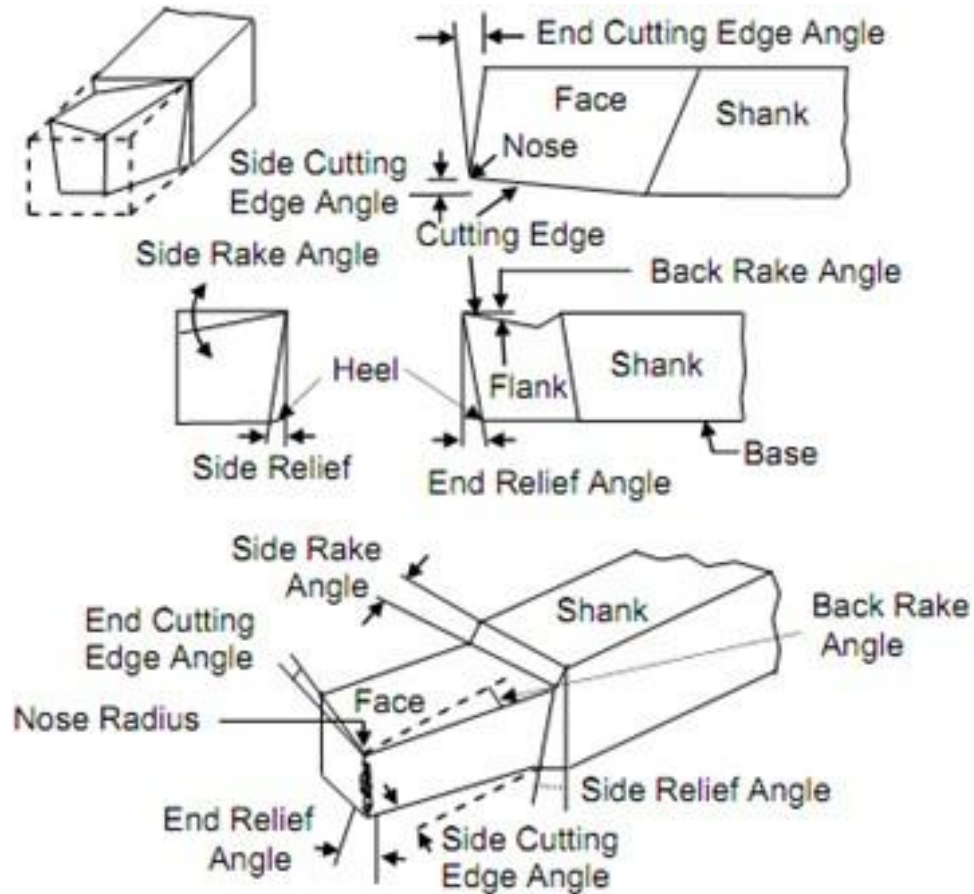

Signature: The shape of a tool is specified in a special sequence and this special sequence is called tool signature. The tool signature as per ASA is given below

- (i) Back rake angle
- (ii) Side rake angle
- (iii) Clearance or End Relief angle
- (iv) Side Relief angle
- (v) End cutting edge angle
- (vi) Side cutting edge angle
- (vii) Nose radius

A typical tool signature of single point cutting tool is 0-7-6-8-15-16-0.8. Here this tool signature indicates that the tool has 0, 7, 6, 8, 15, 16 degree back rake, side rake, end relief, side relief, end cutting edge, side cutting edge angle and 0.8 mm nose radius.

PROCEDURE:

1. The work piece of the given material is brought into contact with grinding
2. The top view is obtained by grinding the work piece at end cutting edge angle and side cutting edge angle.
3. The front view is obtained by grinding at back rake angle and end relief angle.
4. The side view is obtained by grinding at side rake angle and side relief angle.
5. The nose radius is obtained by grinding the tip.
6. Hence the grinding of tool is done according to the A.S.A of tool signature

Precautions:

1. The grinding should be done according to the angles prescribed.
2. The tool should be grinded in such a way that it can satisfy the required purpose.

Space For Calculations

RESULT & CONCLUSIONS:

Hence the tool of given signature was manufactured.

VIVA QUESTIONS:

- Explain single point cutting tool nomenclature
- List out types of tool wears.
- Explain Tool material properties
- Mention the effect of cutting fluid on tool life.
- Explain Taylor's Tool life equation.
- Explain the construction of tool cutting grinder.



Estd: 2008

METHODIST

COLLEGE OF ENGINEERING & TECHNOLOGY

Approved by AICTE New Delhi | Affiliated to Osmania University, Hyderabad

Abids, Hyderabad, Telangana, 500001